

Polystone® M (PE-UHMW/PE 1000)

Extrudierte Profile Extruded Profiles



Inhalt

Content

Einzigartige Auswahl	2 – 3
Polystone® M (PE-UHMW/PE 1000)	4 – 7
Weiterverarbeitung und Service	8
Forschung und Entwicklung	9 – 10
LubX® Hochleistungs-Gleitwerkstoffe	11
LubX® CV Für höhere Geschwindigkeit und Produktivität	12 – 13
Z-Profile	14
L-Profile (Winkel)	15
Klemmprofile	16 – 18
T-Profile	19
U-Profile	20 – 23
C-Profile	24 – 28
Halbrund-Profil	29
Rohre	30
Seitenführungsprofile	31
Vierkant-Profile	32
Clip-Profile	33
Spezial-Profile	34 – 35
Bandmaterial	36
Folien	37
Technische Daten	38
Allgemeine Hinweise	39

Unique selection	2 – 3
Polystone® M (PE-UHMW/PE 1000)	4 – 7
Finishing and service	8
Research and development	9 – 10
LubX® High performance friction materials	11
LubX® CV For higher speed and better productivity	12 – 13
Z-profiles	14
L-profiles (angles)	15
Clamp-profiles	16 – 18
T-profiles	19
U-profiles	20 – 23
C-profiles	24 – 28
Round bar cover	29
Tubes	30
Side guide profile	31
Square-profiles	32
Clip-profiles	33
Special-profiles	34 – 35
Wear strips	36
Film	37
Technical Data	38
General Information	39

Index

R1	19	R74	32	R146	20	R234	23	R341	24	R424	14	R595	22	R720	21
R2	19	R75	32	R148	20	R235	22	R344	20	R425	29	R597	33	R721	19
R3	19	R76	23	R149	19	R236	22	R345	23	R428	27	R598	33	R726	28
R4	19	R77	33	R150	23	R237	16	R346	30	R430	27	R603	25	R727	25
R5	19	R78	31	R151	15	R240	27	R347	30	R431	24	R608	22	R729	20
R6	19	R79	19	R152	14	R241	21	R348	30	R435	15	R615	14	R730	32
R7	14	R87	33	R154	15	R242	34	R351	18	R437	19	R617	17	R734	22
R7.1	15	R88	34	R155	16	R244	25	R352	18	R441	21	R619	24	R735	29
R8	14	R89	34	R156	33	R245	26	R353	27	R443	27	R620	27	R740	17
R9	14	R90	33	R157	33	R246	20	R358	30	R479	32	R621	27	R741	17
R10	16	R94	25	R158	19	R247	22	R359	15	R480	32	R626	24	R742	17
R10.1	16	R95	29	R160	25	R249	33	R361	35	R481	32	R634	14	R743	17
R11	29	R97	29	R167	23	R250	33	R363	27	R485	31	R636	15	R744	24
R12	34	R98	20	R169	23	R251	34	R365	34	R511	30	R647	22	R745	17
R13	31	R102	19	R170	16	R252	35	R366	30	R515	34	R648	16	R746	17
R14	31	R107	17	R172	24	R253	35	R367	30	R519	18	R651	20	R749	18
R15	24	R108	17	R173	21	R255	21	R368	30	R523	23	R655	21	R750	25
R16	24	R111	27	R176	32	R256	21	R369	22	R527	20	R658	18	R751	17
R18	25	R112	24	R180	17	R260	25	R372	22	R528	28	R660	23	R756	23
R19	25	R113	26	R182	15	R265	25	R373	25	R529	20	R661	30	R757	27
R21	24	R115	27	R183	32	R267	15	R374	16	R530	21	R665	31	R758	27
R22	28	R116	34	R184	32	R269	20	R381	24	R533	24	R667	16	R759	25
R23	21	R117	20	R187	14	R272	28	R383	30	R534	17	R668	25	R764	21
R24	20	R119	16	R188	26	R275	16	R386	23	R535	14	R669	30	R765	28
R26	23	R120	25	R190	15	R276	25	R387	17	R536	24	R671	22	R768	20
R28	23	R123	20	R196	33	R283	29	R389	35	R542	15	R672	14	R769	17
R29	22	R124	14	R197	33	R289	25	R390	30	R543	17	R673	22	R770	28
R33	31	R125	15	R203	32	R293	14	R393	17	R545	24	R674	25	R772	27
R35	31	R126	26	R205	14	R294	34	R395	26	R546	18	R676	26	R773	20
R42	23	R127	24	R206	16	R295	19	R396	26	R547	18	R678	22	R774	29
R48	34	R128	20	R207	31	R296	20	R397	26	R548	28	R679	26	R777	28
R51	19	R129	26	R210	21	R300	26	R399	18	R552	14	R680	30	R782	33
R51.1	19	R130	26	R211	14	R301	26	R401	31	R554	27	R690	16	R783	24
R54	15	R131	26	R212	34	R306	19	R402	31	R556	14	R691	27	R785	27
R63	20	R132	20	R213	23	R307	30	R403	31	R557	21	R700	21	R786	27
R64	26	R133	19	R214	26	R308	30	R404	15	R558	31	R703	15	R788	22
R65	34	R134	34	R216	21	R310	14	R405	15	R570	26	R704	18	R790	25
R66	34	R135	34	R217	16	R313	26	R406	14	R571	27	R705	16	R792	17
R67	34	R136	34	R218	16	R314	30	R407	16	R572	26	R706	22	R793	17
R68	23	R137	15	R219	21	R326	34	R408	21	R576	35	R707	22	R794	16
R69	32	R138	16	R220	22	R330	26	R412	27	R579	27	R712	17	R802	21
R70	32	R139	34	R221	22	R331	24	R413	21	R585	25	R715	33	R805	22
R71	32	R140	19	R226	24	R338	24	R417	21	R591	35	R716	25		
R72	32	R141	15	R227	24	R339	17	R421	15	R592	29	R717	22		
R73	32	R143	34	R231	20	R340	16	R422	16	R594	21	R718	32		

Einzigartige Auswahl an extrudierten Profilen aus Polystone® M (PE-UHMW/PE 1000)

Einzigartige Auswahl

Entwickler und Hersteller von Anlagen und Maschinen in der Förder- und Handhabungstechnik, der Lager- und Verpackungsindustrie sowie der Getränke- und Abfüllindustrie setzen auf Bauteile aus thermoplastischen Kunststoffen. Extrudierte Profile sind dabei ein wichtiger Bestandteil. Sie sind dort im Einsatz, wo gute Gleiteigenschaften bei gleichzeitig großer Verschleiß- und Abriebfestigkeit verlangt werden.

Ob Abdeck- oder Clip-Profil, Z-, L-, U-, C-, T- oder Vierkantprofil, ob komplexe Geometrien, spezielle Oberflächenstrukturen oder dünne Wandstärken – Ihnen steht das umfangreichste Fertigungsprogramm an extrudierten Standardprofilen oder individuell für Sie gefertigten Sonderprofilen zur Verfügung. Unser erfahrenes Team berät Sie umfassend bei der Auswahl des richtigen Querschnitts.

Unique selection of extruded profiles made of Polystone® M (PE-UHMW/PE 1000)

Unique selection

Developers and manufacturers of plant and machinery used in conveyor and material handling technology, the storage and packaging industry and the bottling and beverage industry rely on thermoplastic components. Extruded profiles are a key part of these. They are used wherever good slide characteristics are demanded alongside high wear and abrasion resistance.

Whether you need cover- or clip-profiles, Z-, L-, U-, C-, T- or square-profiles, complex geometries, special surface structures or thin wall thicknesses, you can choose from the most extensive range of extruded standard profiles or special profiles customised just for you. Our experienced team will provide comprehensive advice to help you select the right cross-section.



Prozess der Profilextrusion

Bei der Profilextrusion wird der Rohstoff – eine Pulvermischung aus PE-UHMW, Additiven und Farbpigmenten – unter hohem Druck durch ein beheiztes Werkzeug gedrückt. Das Material wird plastisch und nimmt die Form des Werkzeuges an. Nach Verlassen des Werkzeuges ist ein kontrolliertes Abkühlen wichtig, um innere Spannungen auszugleichen und ein Verziehen des Profils zu vermeiden.

Bei hoher Temperatur dehnt sich der Werkstoff aus und zieht sich beim anschließenden Erkalten wieder zusammen. Daher ist die exakte Auslegung des Werkzeuges besonders wichtig, um im fertigen Profil die Form und die vorgegebenen Toleranzen einzuhalten.

The profile extrusion process

In profile extrusion, the raw material – a powder mixture of PE-UHMW, additives and colouring pigments – is forced through a heated tool under high pressure. The material becomes plastic and takes on the form of the tool. After leaving the tool, controlled cooling is essential in order to equalize internal stresses and prevent the profile warping.

The material expands at high temperature and then contracts again as it subsequently cools down. This means it is particularly important to configure the tool precisely so that the form and prescribed tolerances are kept in the finished profile.

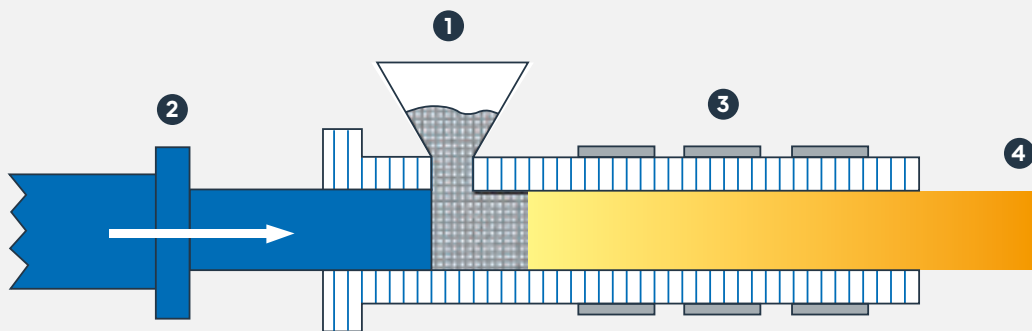

- 1 Trichter:** Polystone® M (PE-UHMW/PE 1000) wird in Form einer Pulvermischung über einen Trichter zugeführt
Funnel: Polystone® M (PE-UHMW/PE 1000) is fed in as a powder mixture through a funnel
- 2 Hydraulikzylinder:** Der Kolben transportiert das Pulver unter hohem Druck in das Werkzeug
Hydraulic cylinder: The piston transports the powder into the tool under high pressure
- 3 Werkzeug:** Das beheizte Werkzeug gibt dem Profil den gewünschten Querschnitt
Tool: The heated tool gives the profile its desired cross-section
- 4 Abkühlen und Zuschnitt:** Abkühlen Ihres Profils und Zuschneiden auf die gewünschte Länge
Cooling and blank cutting: Your profile is cooled and cut to the desired length

Polystone® M (PE-UHMW/PE 1000)

Polystone® M ist ein Werkstoff mit außergewöhnlichen Eigenschaften. Das ultrahochmolekulare Polyethylen löst als extrudiertes Profil Reibungs-, Verschleiß- und Materialflussprobleme in zahlreichen technischen Anwendungen. Die moderne Förder- und Handhabungstechnik, Lager- und Verpackungssysteme oder die Getränke- und Abfüllindustrie kommen heute ohne diesen Hochleistungswerkstoff nicht mehr aus.



Hervorragende Gleiteigenschaften

Dank des geringen Gleitreibungskoeffizienten können extrudierte Profile aus Polystone® M die **benötigte Antriebsenergie** in Fördersystemen **reduzieren** und die Stabilität der **Prozesse erhöhen**. Dabei verfügt Polystone® M über dauerhaft selbstschmierende Eigenschaften.



Extreme Verschleißfestigkeit/Lange Betriebsdauer

Aufgrund der extrem hohen Verschleißfestigkeit halten extrudierte Profile aus PE-UHMW hohen Beanspruchungen langfristig stand.



Dauer-Einsatztemperatur von -250 bis +80 °C

Extrudierte Profile von Röchling sind in einer Vielzahl an Anwendungen mit hohen und sehr niedrigen Temperaturen im Einsatz: beispielsweise in Spiralfrosteren oder Kühlhäusern.



Umweltschonend durch 100 %ige Recyclingfähigkeit



Lebensmitteltauglichkeit bereits für viele Rezepturen verfügbar (gem. EU 10/2011 und FDA)



Hohe Schlagzähigkeit

Polystone® M (PE-UHMW/PE 1000)

Polystone® M is a material with exceptionally properties. As an extruded profile, this polyethylene of ultrahigh molecular weight solves problems of friction, wear and material flow in countless technical applications. Modern conveyor and material handling technology, storage and packaging systems and the bottling and beverage industry could not do without this high-performance material today.



Outstanding slide characteristics

Their low slide friction coefficients enable extruded profiles made of Polystone® M to **reduce the drive energy** required in conveyor systems and **increase the stability of processes**. Polystone® M also has particularly long-lasting self-lubrication properties.



Extreme wear resistance/long service life

Extruded profiles made of PE-UHMW can withstand high long-term stresses thanks to their extremely high wear resistance.



Continuous operating temperature from -250 to +80 °C

Extruded profiles from Röchling are used in a large number of applications involving high and very low temperatures, such as spiral frosters or cold stores.



Environmentally friendly 100 % recyclable



Suitability for use with foods already available for many recipes (as per EU 10/2011 and FDA)



High impact strength

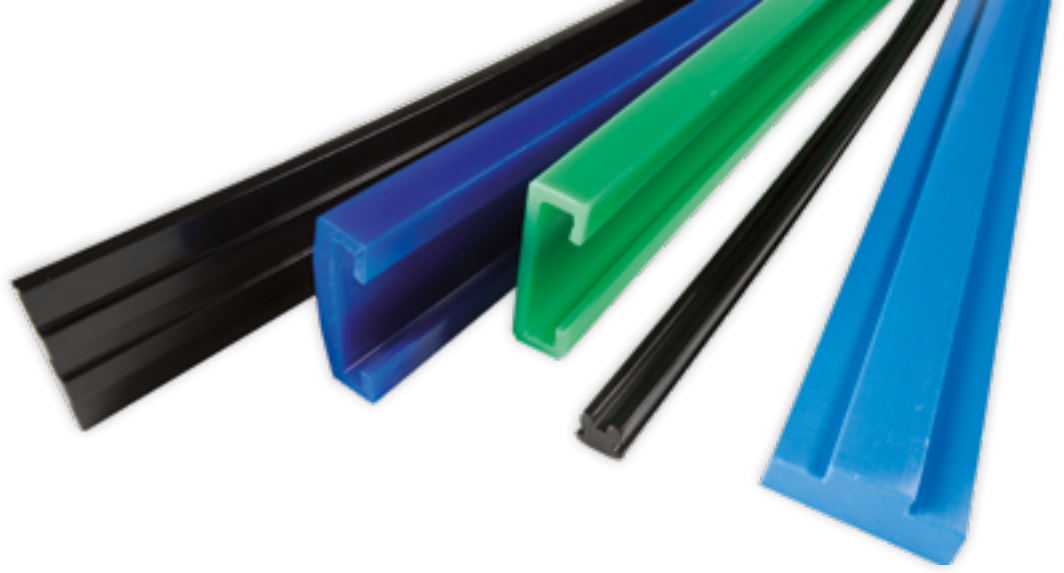

Weitere Eigenschaften von extrudierten Profilen aus Polystone® M:

- Sehr gute Beständigkeit gegen Chemikalien
- Fast keine Wasseraufnahme
- Hohe Widerstandsfähigkeit gegen Bruch oder Rissbildung
- Nur geringfügige Anhaftung an den Oberflächen

Zahlreiche Modifikationen möglich:

- Antistatisch (AST)
- Flammhemmend ausgestattet
- Antimikrobiell ohne Einsatz toxischer Zusätze
- Glaskugelgefüllt
- Nahezu jede gewünschte Farbe herstellbar
- Gleitmittelmodifiziert
- Hitzestabilisiert (reduzierte Wärmealterung)
- UV-stabilisiert

Other properties of extruded profiles made of Polystone® M:

- Very high resistance to chemicals
- Almost no moisture absorption
- High resistance to fracture or cracking
- Only slight adhesion to surfaces

Numerous modifications possible:

- Antistatic (AST)
- Flame retardant finish
- Antimicrobial without the use of toxic additives
- Glass bead filling
- Almost any colour desired can be produced
- Lubricant modified
- Heat stabilised (reduced heat ageing)
- UV resistant

Einzigartige Fertigungsmöglichkeiten

Wir fertigen Ihre Profile auf modernsten Extrusionsanlagen mit im Markt einzigartigen Fertigungsmöglichkeiten: Ob Abdeck- oder Clip-Profil, Z-, L-, U-, C-, T- oder Vierkantprofil, ob komplexe Geometrien, dünne Wandstärken oder hochglänzende und besondere Oberflächenstrukturen – Ihnen steht das im Markt wohl umfangreichste Fertigungsprogramm an Standardprofilen oder für Sie exklusiv gefertigten Sonderprofilen zur Verfügung.

Beratung und eigener Werkzeugbau

Bei Entwicklung und Design Ihres Spezialprofils nach Ihren individuellen Vorgaben beraten Sie unsere erfahrenen Techniker und Werkzeugbauer, um ein optimal funktionierendes Ergebnis für Ihre Anwendung zu erzielen. Unser eigener Werkzeugbau bietet dabei höchste Präzision, Schnelligkeit und eine optimale Abstimmung des Werkzeugs auf den verwendeten Kunststoff.

Unique manufacturing options

We manufacture your profiles on the very latest extrusion systems with unique manufacturing options: whether you need cover- or clip-profiles, Z-, L-, U-, C-, T- or square-profiles, complex geometries, thin wall thicknesses or high-gloss and special surface structures, you can choose from the most extensive range of standard profiles or special profiles customised exclusively for you.

Consulting and in-house toolshop

Our experienced engineers and toolmakers will give you advice on how to design and develop your special profile to meet your own particular requirements so that you achieve the outcome that works best for your application. Our in-house toolshop offers maximum precision, speed and the optimum configuration of the tool to the plastic used.



Zahlreiche Vorteile

- In den meisten Fällen deutlich günstiger als das zerspante Profil
- Eigener Werkzeugbau
- Komplexe Geometrien möglich
- Querschnitte realisierbar, die nicht spanabhebend hergestellt werden können
- Dünne Wandstärken ab 1,5 mm
- Keine Längenbegrenzung
- Kein Materialverlust
- Homogene, glatte Oberfläche



Numerous advantages

- In most cases much cheaper than machined profiles
- In-house toolshop
- Complex geometries possible
- Possibility of cross-sections that cannot be produced by machining processes
- Thin wall thicknesses from 1.5 mm
- No limits on length
- No loss of material
- Smooth, homogeneous surface

Die Fertigung von Profilen im Extrusionsverfahren bietet im Vergleich zur spanabhebenden Herstellung je nach Profilquerschnitt **Vorteile** hinsichtlich der **Wirtschaftlichkeit** und **technischen Realisierbarkeit**.

Depending on the profile cross-section, the manufacture of profiles in an extrusion process offers advantages over machining processes in terms of **economy** and **technical feasibility**.

Wirtschaftlichkeit Economy

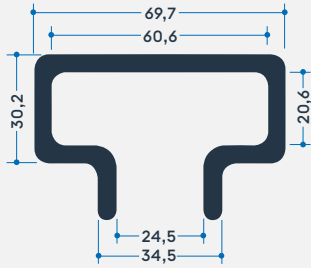

R343
C-Profil
C-profile

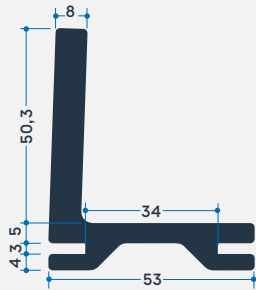

R361
Spezial-Profil
Special-profile

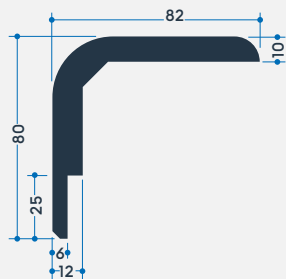

R259
Spezial-Profil
Special-profile

Beispiele für Profile, die bei spanabhebender Fertigung einen hohen Materialverlust und Zerspannungsaufwand verursachen und deswegen wirtschaftlich nicht gefertigt werden können. Die Extrusion bietet hier einen klaren Vorteil, da Profile mittels eines Formwerkzeuges produziert und somit ohne jeglichen Materialverlust hergestellt werden.

Examples of profiles that entail significant loss of material and machining expenditure in machining processes and so cannot be manufactured cost-effectively. Extrusion offers a clear advantage here as profiles can be produced using a die, meaning there is no loss of material whatsoever.

Technische Realisierbarkeit Technical feasibility

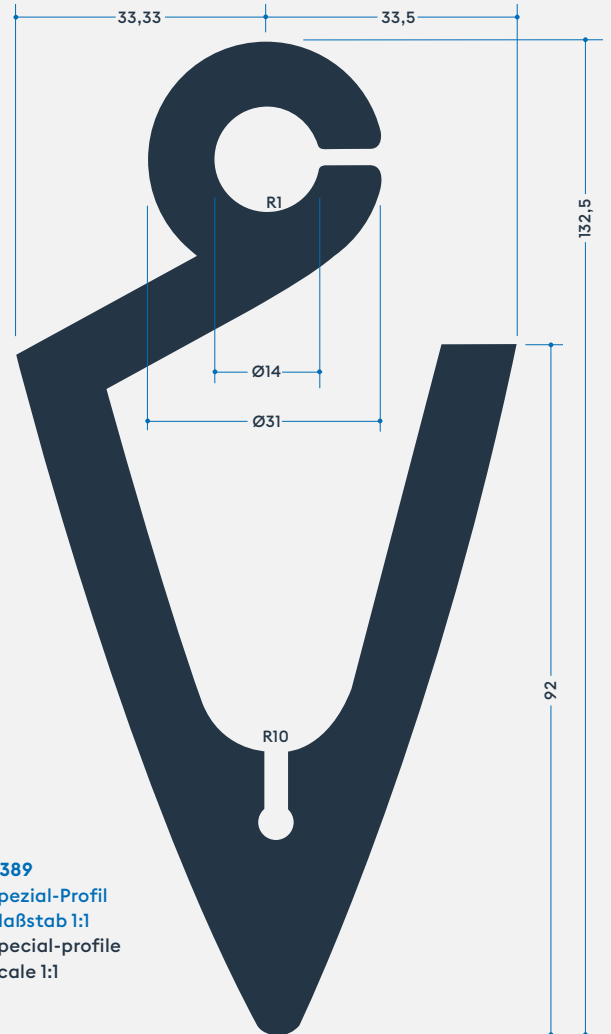

R389
Spezial-Profil
Maßstab 1:1
Special-profile
Scale 1:1

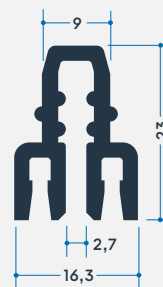

R242
Spezial-Profil
Maßstab 1:1
Special-profile
Scale 1:1

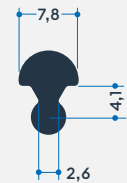

R355
Spezial-Profil
Maßstab 1:1
Special-profile
Scale 1:1

Beispiele für Profile, die aufgrund der Geometrie spanabhebend nicht oder nur sehr aufwendig hergestellt werden können. Im Extrusionsverfahren gibt es diesbezüglich kaum Beschränkungen und es kann daher fast jede erdenkliche Profilform problemlos realisiert werden.

Examples of profiles whose geometry makes it impossible or complex to produce in machining processes. There are hardly any restrictions in this regard in an extrusion process, so almost every conceivable profile form can be realised without any problem.

Weiterverarbeitung und Service

Unsere Weiterverarbeitungsmöglichkeiten und unser Service runden das umfangreiche Angebot an extrudierten Profilen ab:

- Stanzen von Befestigungslöchern und Profilendkonturen
- Einbringen von Bohrungen und Einschraubbohrungen
- Kombination mit Stahlprofilen
- Spanende Endbearbeitung des extrudierten Profils
- Zuschnitt auf Länge
- Lieferung auf Rolle

Zerspante Profile

Für Prototypen oder Bedarfsmengen, für die die Erstellung eines Extrusionswerkzeuges nicht wirtschaftlich ist, können wir Profile auch durch spanabhebende Bearbeitung herstellen. Hierfür setzt Röchling moderne Profilfräsmaschinen ein, mit denen auch anspruchsvolle Querschnitte hergestellt werden können. Als Hersteller von Kunststoffhalbzeugen verfügen wir über die notwendigen hochwertigen Materialien.

Finishing and service

The comprehensive range of extruded profiles is rounded off by finishing options and our package of services:

- Punching fixing holes and profile end contours
- Insertion of screw and plain holes
- Combination with steel profiles
- Final machining of the extruded profile
- Cutting to length
- Supplied as a roll

Machined profiles

For prototypes or quantities for which the manufacture of an extrusion tool is not economically viable, we can also produce profiles through machining processes. To do so Röchling uses modern profile milling machines that allow even complex cross-sections to be produced. As a manufacturer of semi-finished plastic products, we have the high-grade materials required.

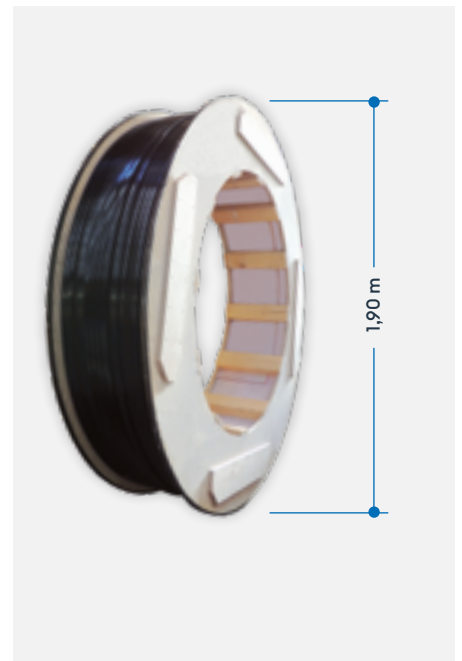
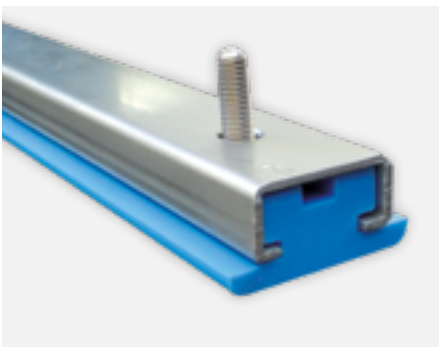
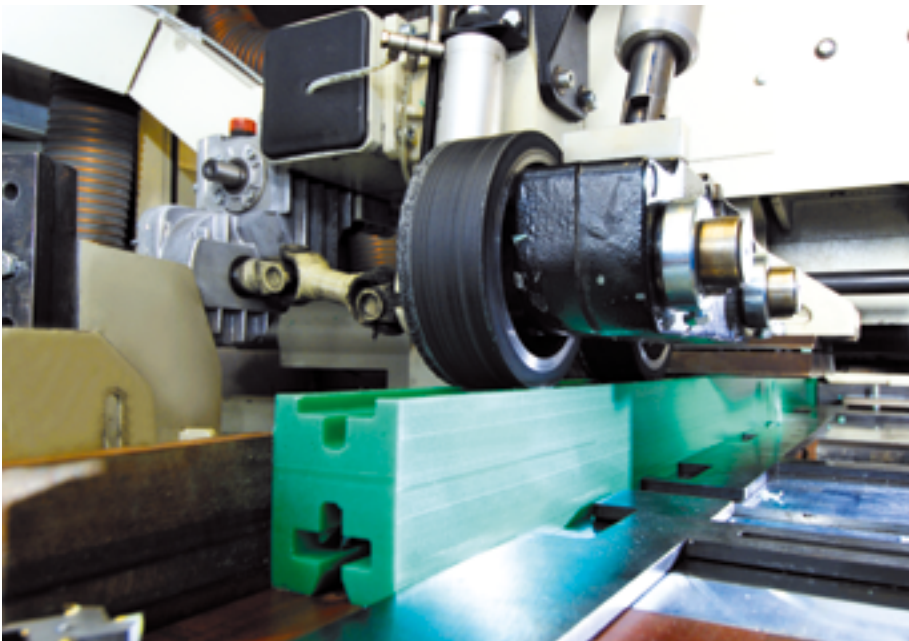

Forschung und Entwicklung

Research and development

Mehrwert für unsere Kunden

- Produkt- und Werkstoffentwicklung
- Modifikation bestehender Rezepturen
- Praxisnahe Versuchsanlagen
- Zusammenarbeit mit Wissenschaftlern
- Moderne Werkstofflabors

More value for our customers

- Product and materials development
- Modification of existing compositions
- Practical testing facilities
- Cooperation with scientists
- State-of-the-art materials laboratory



Wettbewerbsvorteile durch Innovation

Das Thema Innovation hat bei Röchling höchste Priorität. So präsentieren wir dem Markt Produktentwicklungen, die unseren Kunden Wettbewerbsvorteile bieten.

In unseren gut ausgestatteten Werkstofflabors und in enger Kooperation mit Lieferanten, Wissenschaftlern und Instituten entwickeln wir zu den Aufgabenstellungen unserer Kunden neue Produkte und Herstellungsverfahren.

Das Qualitätsmanagementsystem unserer Unternehmen nach DIN EN ISO 9001 wird regelmäßig in Audits überprüft und dessen Einhaltung sichergestellt. Außerdem unterziehen wir unsere Produkte in allen Phasen des Produktionsprozesses permanenten Kontrollen.

Durch die Mitarbeit in zahlreichen Gremien und Ausschüssen stellen wir uns aktiv in den Dienst der Branchen und definieren so die Qualitätsstandards der Zukunft.

Competitive advantages through innovation

At Röchling, our top priority is innovation. This allows us to present the market with product developments that provide our customers with competitive advantages.

We develop new products and manufacturing processes to fit the specific problem definitions of our customers in our excellently outfitted materials laboratory, and in close cooperation with suppliers, scientists and institutes.

Our quality management system is regularly inspected in audits in accordance with DIN EN ISO 9001 and its compliance ensured. Moreover, our products undergo ongoing controls in all phases of the production process.

We actively engage in serving the industries through our collaboration with numerous advisory boards and committees, and thus, help define the quality standards of the future.



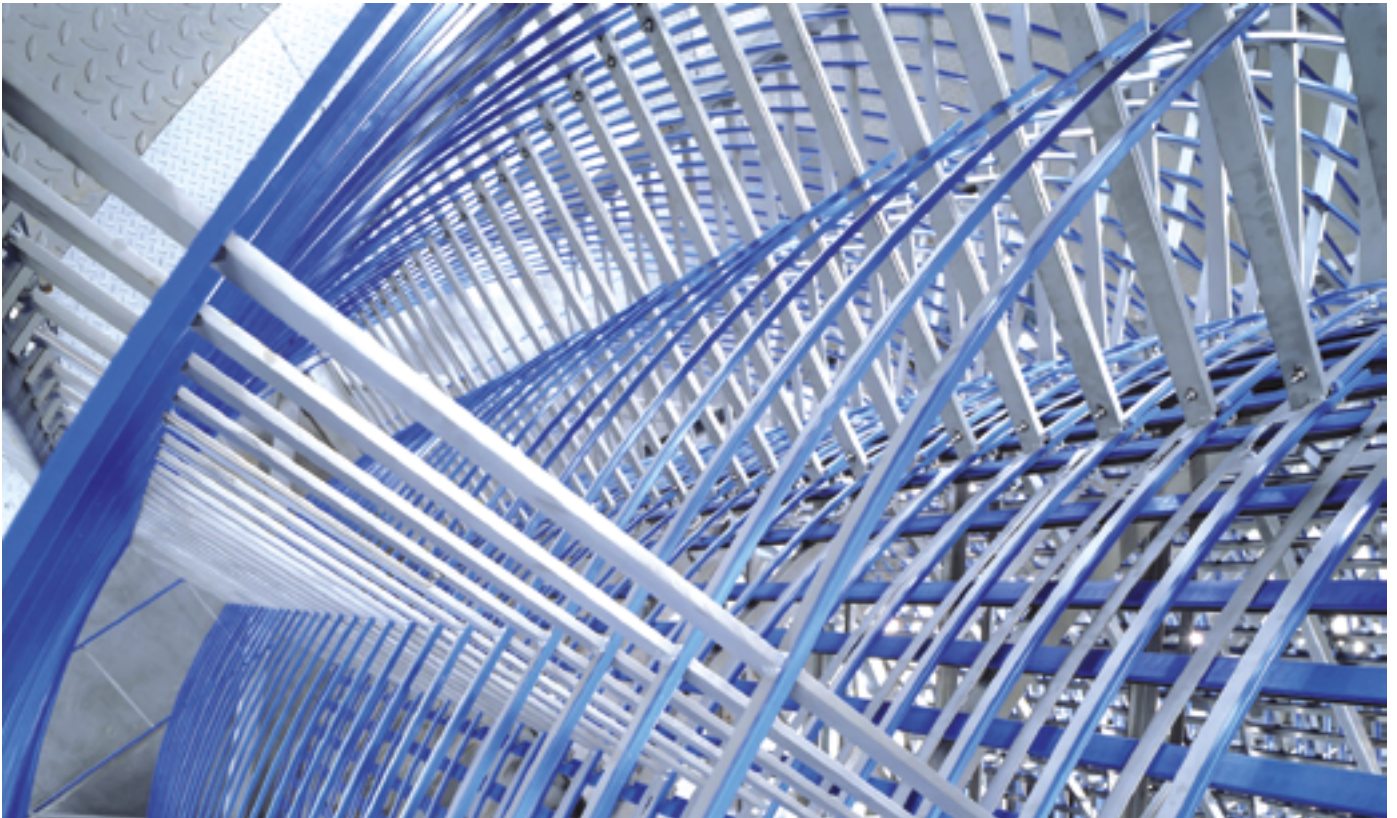

Spiralfroster mit extrudierten Profilen aus LubX®
Spiral froster with extruded profiles made of LubX®

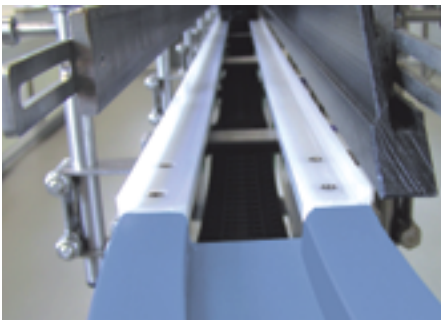

Kurvenführung, LubX® C
Slide guide, LubX® C



Extrudiertes Profil als Handlauf einer Eishockey-Bande
Extruded profile as handrail on an ice hockey board



Kettenführungsprofil
Chain guide profile

Schlitten mit Kufen
aus extrudierten Profilen
Carriage with runners made
from extruded profiles

Spezialprofil für eine
Getränkeabfüllanlage
Special profile for a
drinks bottling plant



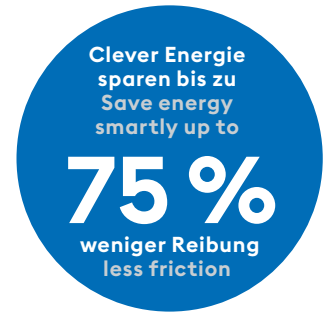

Hochleistungs-Gleitwerkstoffe für Fördertechnik und Automatisierung

High performance friction materials for handling and automation

Energieeffizienz verbessern

Bei langfristig steigenden Energiepreisen spielt die Senkung der Energiekosten bei der Projektierung von Produktions-, Lager- und Logistikprozessen eine immer bedeutendere Rolle. Der Einsatz gleitoptimierter Komponenten in einem Förderprozess kann die benötigte Förderkraft – und somit die eingesetzte Energie – auf ein Minimum verringern. Die Leistungsfähigkeit und Effizienz der Anlage kann so deutlich verbessert werden.

Gleitreibungskoeffizient reduziert

Speziell für Anwendungen in der Förder- und Automatisierungstechnik hat Röchling mit LubX® C und LubX® S zwei neue, PE-1000-basierte Hochleistungswerkstoffe entwickelt, die über herausragende Trockenlaufeigenschaften verfügen. Der Gleitreibungskoeffizient konnte um bis zu 75 % reduziert werden. Im Vergleich zu herkömmlichen Gleitwerkstoffen benötigen mit LubX® ausgestattete Fördersysteme deutlich weniger Energie, die Prozessstabilität wird erhöht und der Geräuschpegel erheblich verringert.

Improve energy efficiency

With energy prices rising in the long term, lowering energy costs plays an increasingly more important role in the project planning of production, storage and logistic processes. When utilising components with optimized sliding properties in conveying processes, the conveying power required – and thus the energy applied – may be reduced to a minimum. The performance and efficiency of the plant can thus be considerably enhanced.

Reduced coefficient of friction

In LubX® C and LubX® S, Röchling has developed two new, PE-1000-based high-performance materials with outstanding dry running properties especially for use in materials-handling technology and automation. The slide friction coefficient has been reduced by as much as 75 %. When compared to conventional slide materials, conveyor systems equipped with LubX® require significantly less energy, process stability is increased and the noise level is considerably reduced.

Gleiteigenschaften im Vergleich

Comparison of sliding properties

Gleitpartner POM
Sliding partner POM

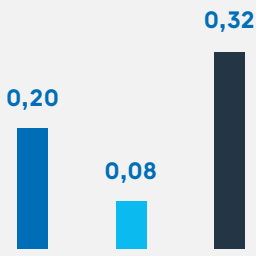

Gleitpartner Stahl
Sliding partner Steel

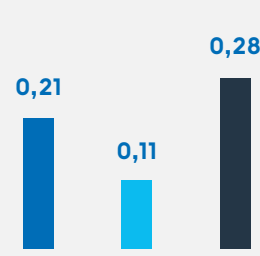

Gleitpartner PET
Sliding partner PET

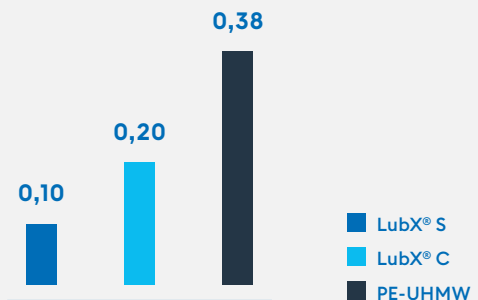

Gleitreibungskoeffizienten unter Trockenbedingungen, auf anwendungsnahem Röchling-Tribologieprüfstand validiert, Geschwindigkeit: 0,25 m/s, Flächenpressung: 0,25 MPa, Prüfzeit: 24 h

Coefficients of sliding friction under dry conditions, validated on the application-related Röchling tribology test stand, Speed: 0,25 m/s, Surface pressure: 0,25 MPa, Test time: 24 h

LubX[®] CV

Für höhere Geschwindigkeit und Produktivität

Mit LubX[®] S und LubX[®] C hat Röchling im Jahr 2012 zwei Gleitwerkstoffe für die Fördertechnik vorgestellt, deren Gleiteigenschaften gezielt auf ihren jeweiligen Gleitpartner hin optimiert wurden.

Speziell für Anlagen, die mit höheren Geschwindigkeiten und somit höherer Produktivität betrieben werden sollen, hat Röchling nun LubX[®] CV entwickelt. LubX[®] CV verfügt über außergewöhnlich gute Gleiteigenschaften bei gleichzeitig niedrigster Temperaturentwicklung. Beides hat einen geringeren Abrieb und eine lange Lebensdauer des gesamten Systems zur Folge.

In wissenschaftlichen Untersuchungen mit der Technischen Universität Chemnitz, Institut für Fördertechnik und Kunststoffe, und der Universität Erlangen, Lehrstuhl für Kunststofftechnik, hat LubX[®] CV den hohen Anspruch bestätigt. Lassen Sie sich von Fakten überzeugen.

For higher speed and better productivity

In 2012 Röchling introduced two sliding materials for the conveyor industry: LubX[®] S and LubX[®] C. Both materials' sliding properties have been optimized specifically for their respective sliding partners.

Röchling has now developed LubX[®] CV: Especially for systems to be operated at higher speeds and therefore higher productivity. LubX[®] CV has exceptionally good sliding properties and at the same time exhibits a very low temperature development. Both results in lower wear and a longer lifespan of the entire system.

In scientific studies in cooperation with the Technical University of Chemnitz, Institute for Material Handling and Plastics, and the University of Erlangen, Institute of Polymer Technology, LubX[®] CV has met the high demands. Let the facts convince you.

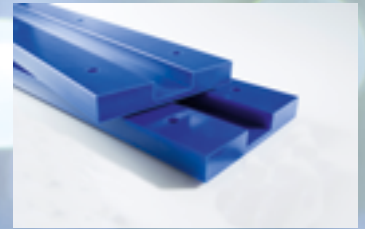

Niedriger Gleitreibungskoeffizient

Die Prüfungen wurden im unternehmenseigenen Werkstofflabor auf einem in Kooperation mit Wissenschaftlern entwickelten Tribologie-Prüfstand durchgeführt. Um das Prüfverfahren an die gesteigerten Anforderungen anzupassen, wurden für den anwendungsnahen Test die Bedingungen deutlich erhöht: Die Geschwindigkeit wurde auf 0,5 m/s und die Flächenpressung auf 0,5 MPa verdoppelt. Unter diesen gestiegenen Anforderungen verfügt LubX[®] CV mit nur μ : 0,13 über den mit Abstand niedrigsten Gleitreibungskoeffizienten und die kürzeste Einlaufphase.

Low Coefficient of Sliding Friction

The tests were carried out at the company's materials laboratory on a tribology test apparatus developed in cooperation with scientists. In order to adapt the test procedure to the increased requirements, the conditions were significantly increased for the application-oriented test: The speed was doubled to 0.5 m/s and the surface pressure was doubled to 0.5 MPa. Under these increased demands LubX[®] CV exhibited by far the lowest coefficient of sliding friction at only μ : 0.13 and the shortest run-in phase.

Gleitreibungskoeffizient Coefficient of Sliding Friction

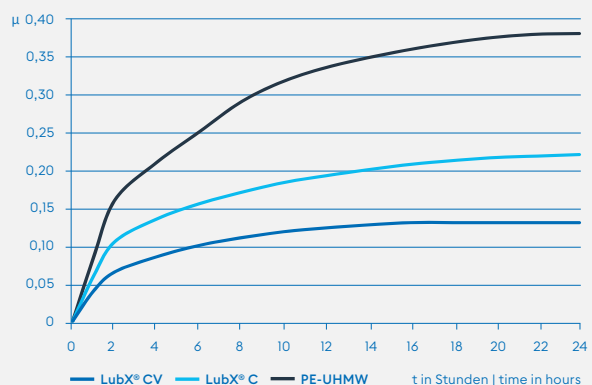

Gleitreibungskoeffizient unter Trockenbedingungen. Auf anwendungsnahem Röchling-Tribologieprüfstand validiert. Geschwindigkeit: 0,5 m/s, Flächenpressung: 0,5 MPa, Prüfzeit: 24 h, Gleitpartner POM

Coefficient of sliding friction under dry conditions, validated on Röchling's application-level tribology test apparatus. Speed: 0.5 m/s, surface pressure 0.5 MPa, test time 24 hours, Sliding partner POM

Für höhere Geschwindigkeit und Produktivität For higher speed and better productivity

Geringe Temperaturentwicklung Low temperature development

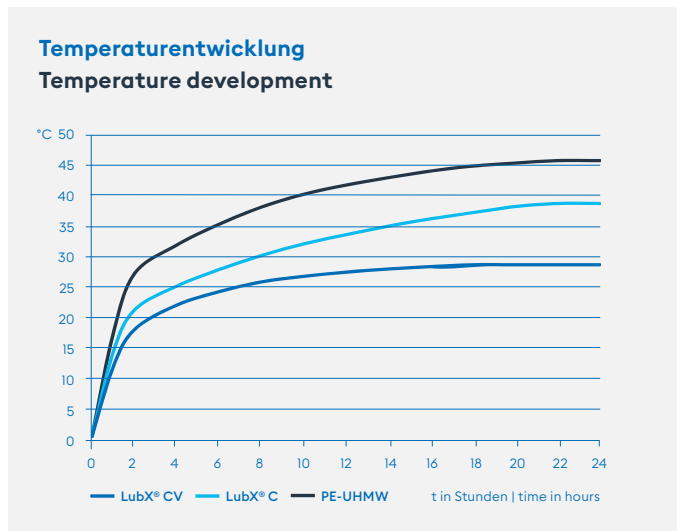

Gleitreibungskoeffizient unter Trockenbedingungen. Auf anwendungsnahem Röchling-Tribologieprüfstand validiert. Geschwindigkeit: 0,5 m/s, Flächen-
 druck: 0,5 MPa, Prüfzeit: 24 h, Gleitpartner POM

Temperature development under dry conditions, validated on Röchling's application-level tribology test apparatus. Speed: 0.5 m/s, surface pressure 0.5 MPa, test time 24 hours, Sliding partner POM

Während der Prüfung des Gleitreibungskoeffizienten misst ein Infrarotsensor (Pyrometer) berührungslos die Temperaturentwicklung direkt auf der Reibfläche der Probe. Die gemessene Temperatur von LubX® CV stieg im Test nicht über 28 °C und lag bis zu 17 °C unter den anderen Werkstoffproben. Zudem zeigt der Prüfkörper aus LubX® CV nach 24 Stunden nahezu **keine Verschleißerscheinungen**.

During the test of the coefficient of sliding friction, an infrared sensor (pyrometer) measures the temperature development directly on the friction surface of the sample without contacting it. The measured temperature of LubX® CV in the test does not rise over 28 °C, which was up to 17 °C below the other material samples. In addition, the LubX® CV sample shows almost **no signs of wear** after 24 hours.

Energie effizient nutzen Efficient energy use

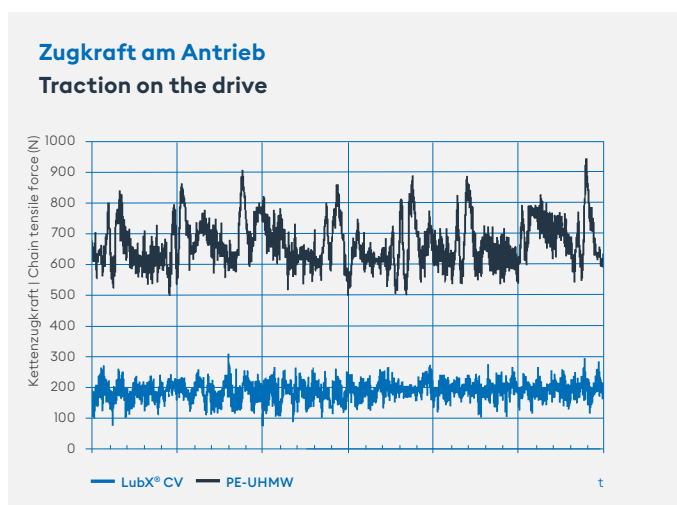

Zugkraft am Antrieb während eines kompletten Kettendurchlaufes. Geschwindigkeit 0,68 m/s. Technische Universität Chemnitz, Institut für Förder-
 technik und Kunststoffe, Gleitpartner POM

Traction on the drive during a complete chain run. Speed 0.68 m/s, Chemnitz University of Technology, Institute for Material Handling and Plastics, Sliding partner POM

Für die Messung der Zugkraft am Antrieb wurde auf einem anwendungsnahen Gleitkettenfördersystem LubX® CV mit einem Standard PE-UHMW im Vergleich getestet. Die Grafik zeigt, dass der gemessene Wert für LubX® CV (Mittelwert = 193 N) bei weniger als 30 % des Wertes für PE-UHMW (Mittelwert = 669 N) liegt.

Die elektrische Energieaufnahme des Antriebs war mit LubX® CV ebenfalls entsprechend niedriger. Die signifikant geringeren Ausschläge der Messkurve für LubX® CV sind zudem ein Beleg für eine deutlich bessere Prozessstabilität und geringere Geräuschentwicklung.

To measure the tensile force on the drive LubX® CV was tested in comparison with a standard PE-UHMW on an application oriented conveyor belt system. The graph shows that the measured value for LubX® CV (mean = 193 N) is less than 30% of the value for PE-UHMW (mean = 669 N).

The electrical energy consumption of the drive was also correspondingly lower with LubX® CV. The significantly lower amplitudes of the measured curve for LubX® CV are also evidence of significantly improved process stability and a lower noise development.

Z-Profile Z-profiles

Rollenlänge ca. 60 m
Length per roll ca. 60 m

Standardlänge: 6000 mm oder Rollenware
Qualitäten: M-natur, M-schwarz, M-grün
(PE-UHMW/PE1000)

Standard length: 6000 mm or in coils
Qualities: M-natural, M-black, M-green
(PE-UHMW/PE1000)

Toleranzen nach
DIN 16941-3a und/oder
gesonderter Vereinbarung

Tolerances according to
DIN 16941-3a and/or
separate agreement

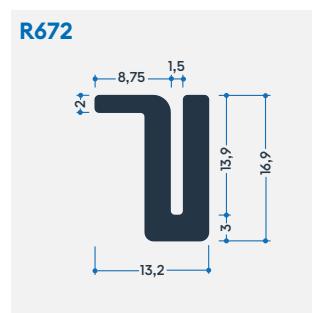
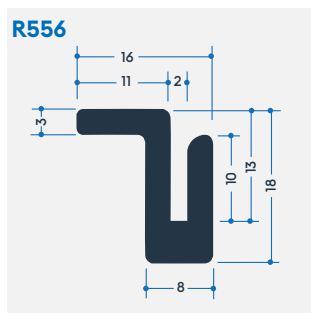
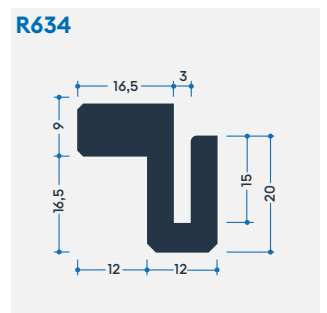
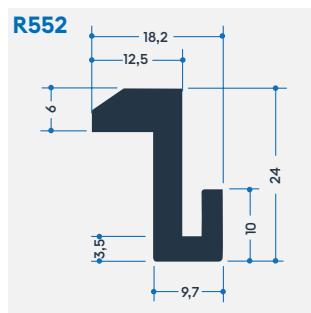
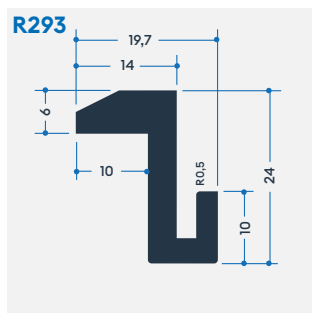
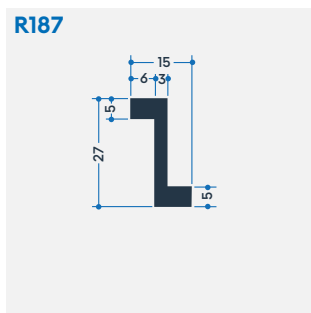
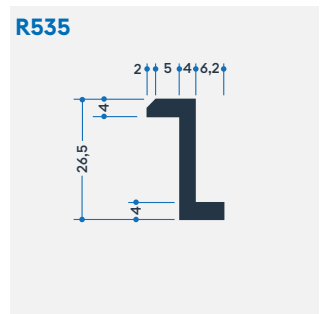
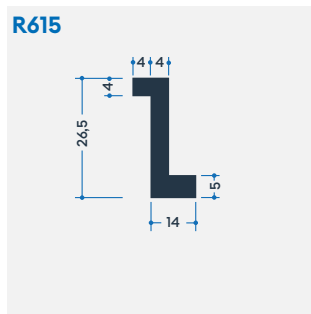
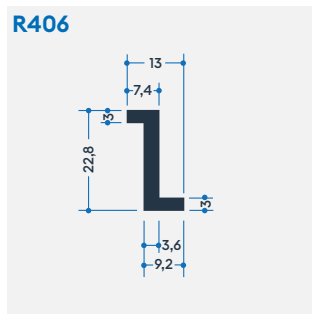
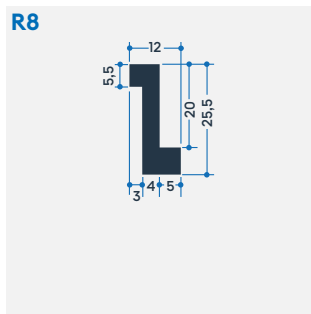
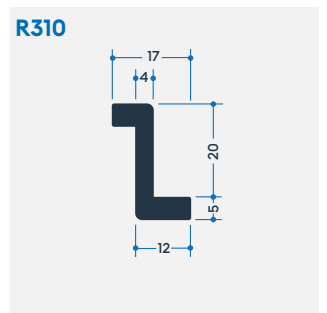
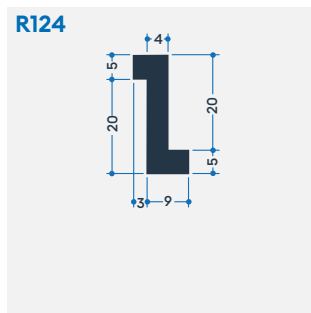
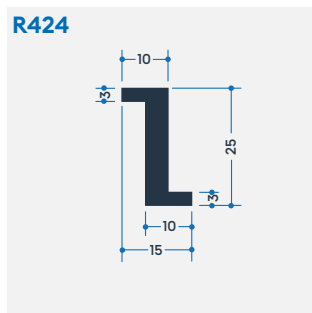
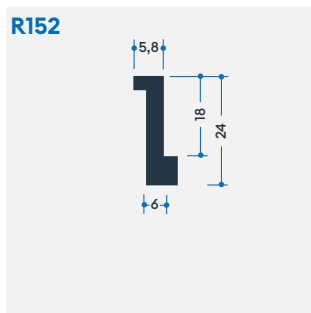
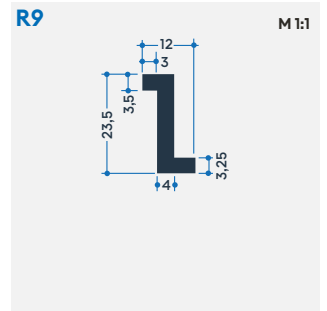
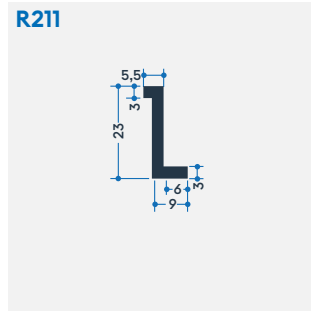
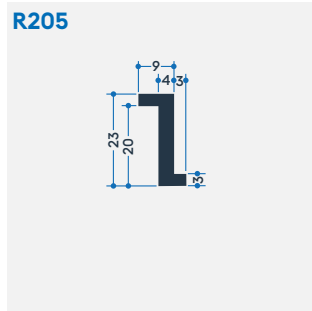
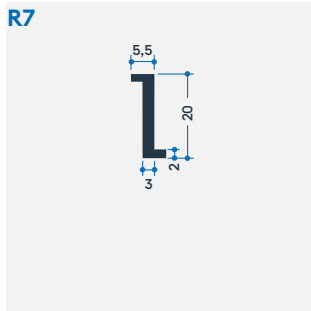

L-Profile (Winkel) L-profiles (angles)

Rollenlänge ca. 60 m
Length per roll ca. 60 m

Standardlänge: 6000 mm oder Rollenware
Qualitäten: M-natur, M-schwarz, M-grün
(PE-UHMW/PE 1000)

Standard length: 6000 mm or in coils
Qualities: M-natural, M-black, M-green
(PE-UHMW/PE 1000)

Toleranzen nach DIN 16941-3a und/oder gesonderter Vereinbarung

Tolerances according to DIN 16941-3a and/or separate agreement

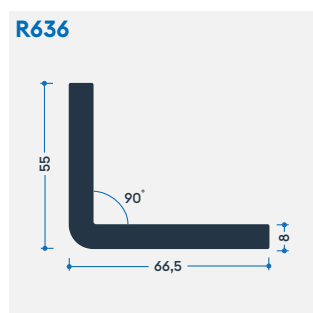
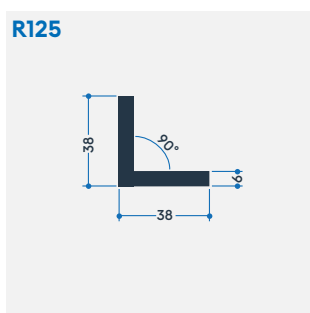
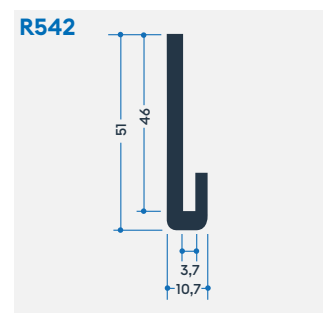
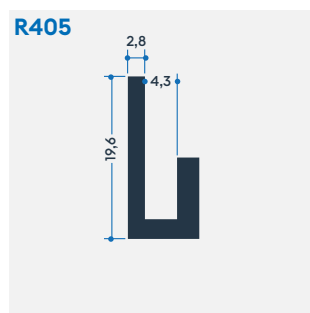
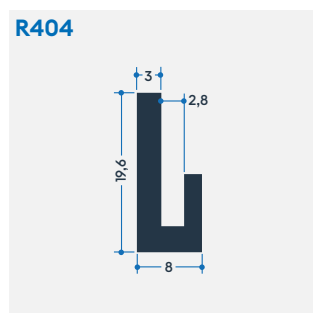
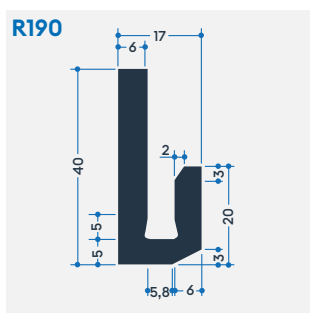
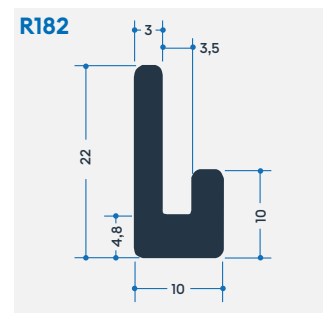
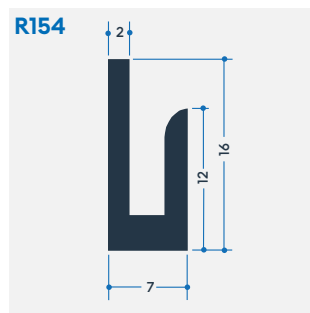
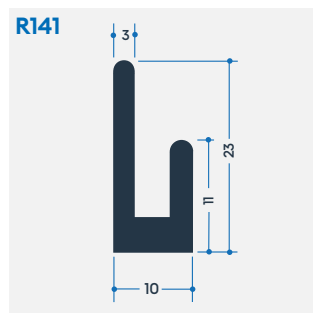
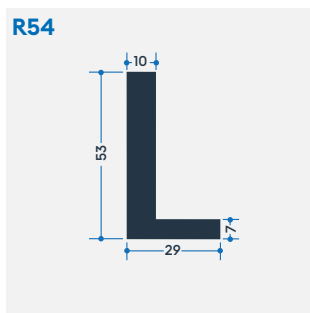
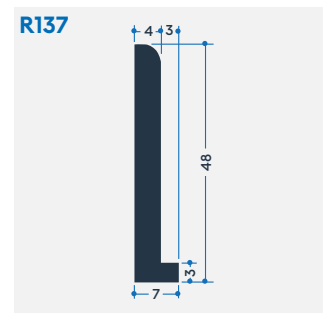
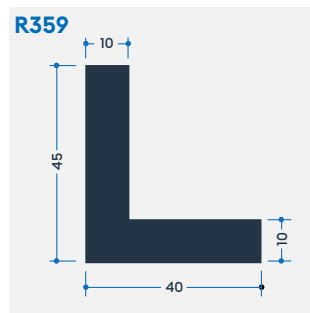
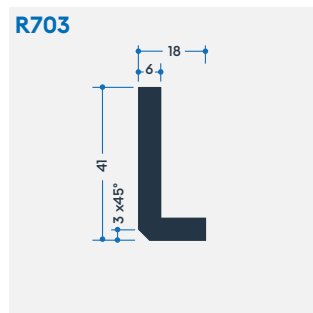
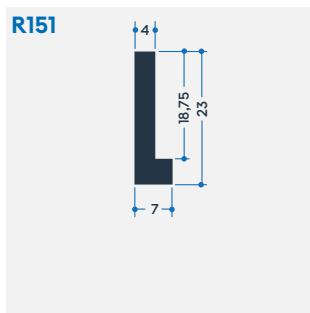
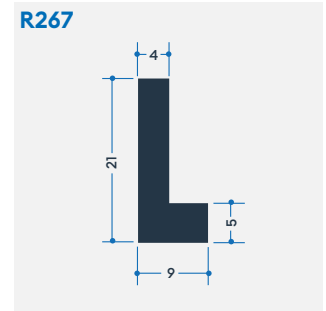
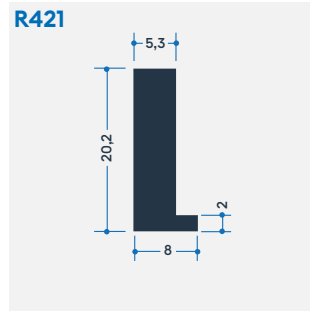
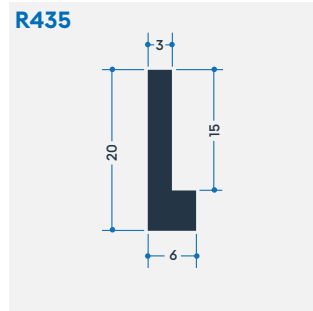
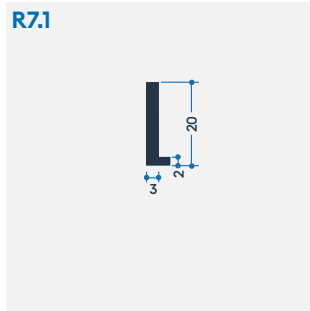

Z-Profil	Z-profiles
L-Profil (Winkel)	L-profiles (angles)
Klemmprofil	Clamp-profiles
T-Profil	T-profiles
U-Profil	U-profiles
C-Profil	C-profiles
Halbrund-Profil	Round bar cover
Rohre	Tubes
Seitenführungsprofil	Side guide profiles
Vierkantprofil	Square-profiles
Clip-Profil	Clip-profiles
Spezial-Profil	Special-profiles
Bandmaterial	Wear strips
Folien	Film

Klemmprofile Clamp-profiles

Rollenlänge ca. 60 m
Length per roll ca. 60 m

Standardlänge: 6000 mm oder Rollenware
Qualitäten: M-natur, M-schwarz, M-grün
(PE-UHMW/PE1000)

Standard length: 6000 mm or in coils
Qualities: M-natural, M-black, M-green
(PE-UHMW/PE1000)

Toleranzen nach DIN 16941-3a und/oder gesonderter Vereinbarung

Tolerances according to DIN 16941-3a and/or separate agreement

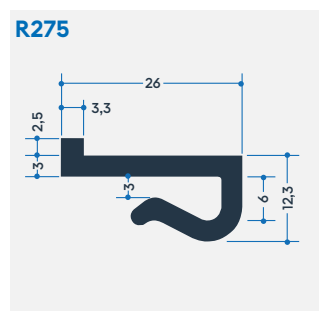
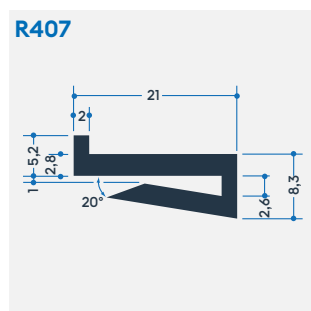
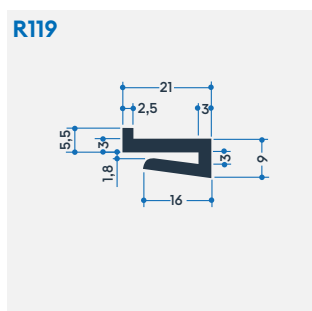
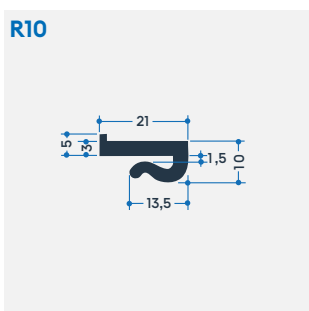
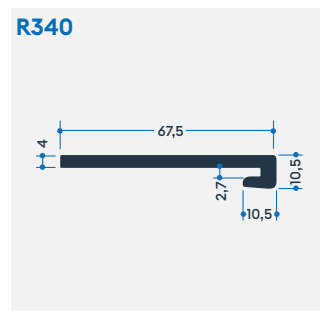
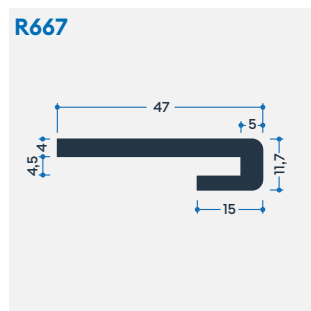
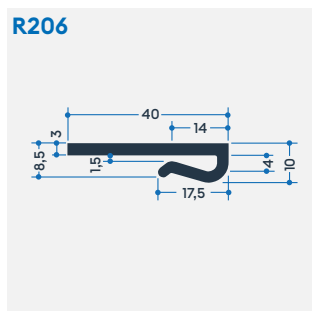
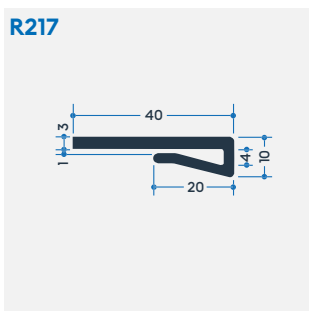
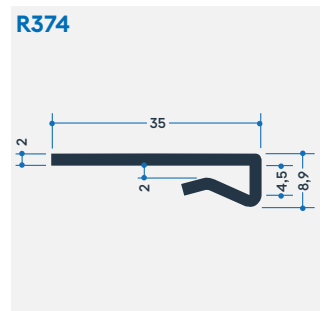
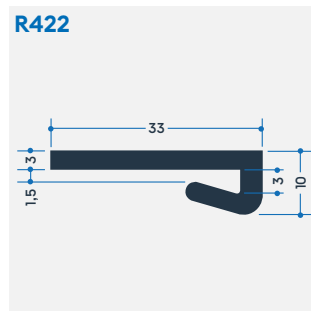
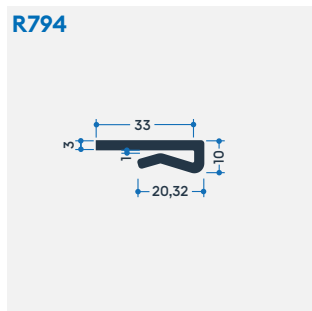
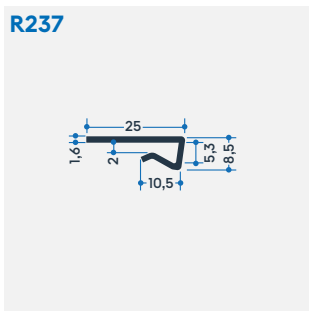
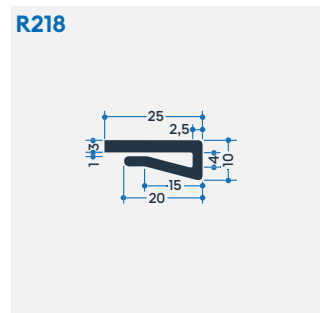
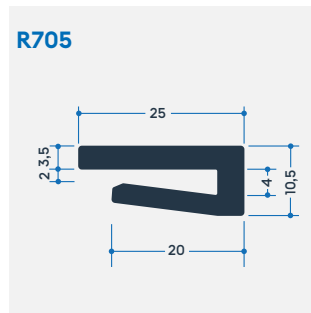
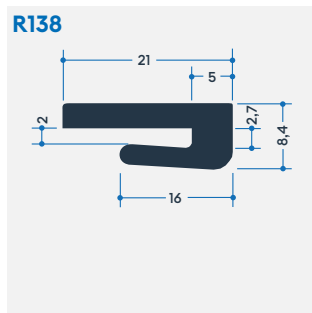
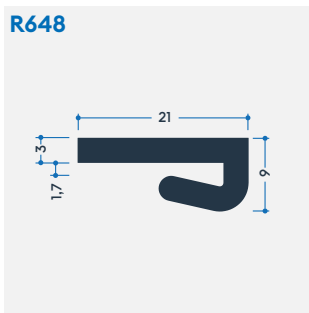
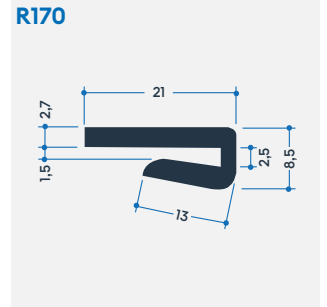
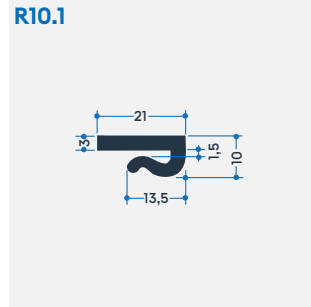
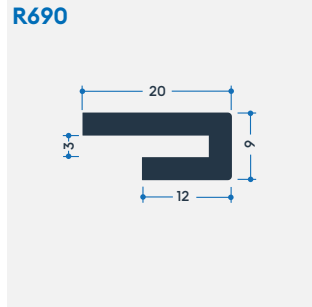
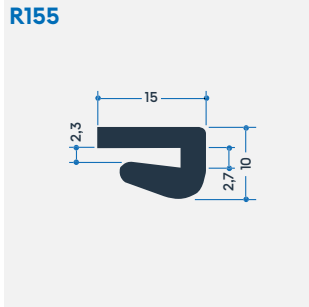

Klemmprofile Clamp-profiles

Rollenlänge ca. 60 m
Length per roll ca. 60 m

Standardlänge: 6000 mm oder Rollenware
Qualitäten: M-natur, M-schwarz, M-grün
(PE-UHMW/PE 1000)

Standard length: 6000 mm or in coils
Qualities: M-natural, M-black, M-green
(PE-UHMW/PE 1000)

Toleranzen nach DIN 16941-3a und/oder gesonderter Vereinbarung

Tolerances according to DIN 16941-3a and/or separate agreement

R534

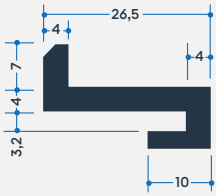

R339

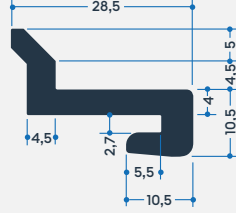

R751

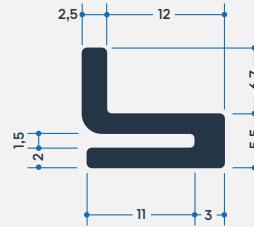

R393

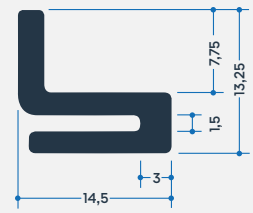

R108

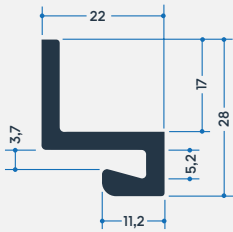

R180

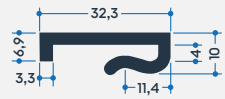

R107

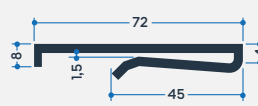

R743

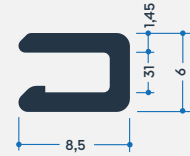

R745



R793



R769



R712

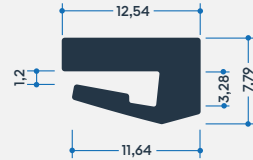

R792

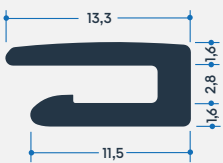

R543

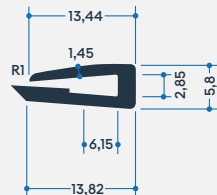

R746

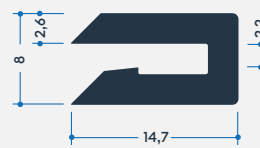

R617

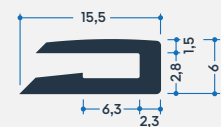

R742



R740

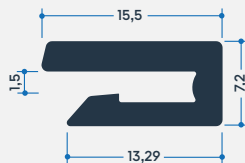

R741

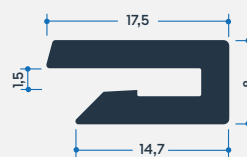

R387

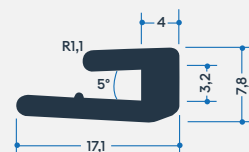

Z-Profil
Z-profiles

L-Profil (Winkel)
L-profiles (angles)

Klemmprofil
Clamp-profiles

T-Profil
T-profiles

U-Profil
U-profiles

C-Profil
C-profiles

Halbrund-Profil
Round bar cover

Rohr
Tubes

Seitenführungsprofil
Side guide profiles

Vierkantprofil
Square-profiles

Clip-Profil
Clip-profiles

Spezial-Profil
Special-profiles

Bandmaterial
Wear strips

Folien
Film

Klemmprofile Clamp-profiles

Rollenlänge ca. 60 m
Length per roll ca. 60 m

Standardlänge: 6000 mm oder Rollenware
Qualitäten: M-natur, M-schwarz, M-grün
(PE-UHMW/PE 1000)

Standard length: 6000 mm or in coils
Qualities: M-natural, M-black, M-green
(PE-UHMW/PE 1000)

Toleranzen nach DIN 16941-
3a und/oder gesonderter
Vereinbarung

Tolerances according to
DIN 16941-3a and/or
separate agreement

R749



R351

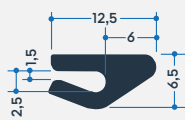

R352

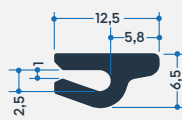

R546

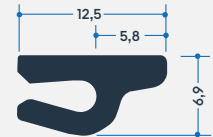

R658

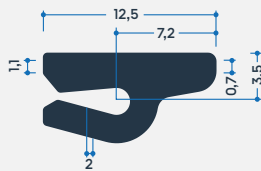

R704

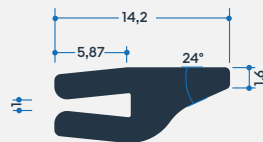

R399

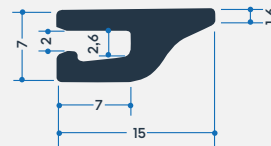

R519

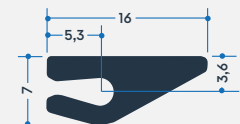

R547

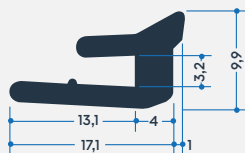

T-Profile T-profiles

Rollenlänge ca. 60 m
Length per roll ca. 60 m

Standardlänge: 6000 mm oder Rollenware
Qualitäten: M-natur, M-schwarz, M-grün
(PE-UHMW/PE 1000)

Standard length: 6000 mm or in coils
Qualities: M-natural, M-black, M-green
(PE-UHMW/PE 1000)

Toleranzen nach DIN 16941-3a und/oder gesonderter Vereinbarung

Tolerances according to DIN 16941-3a and/or separate agreement

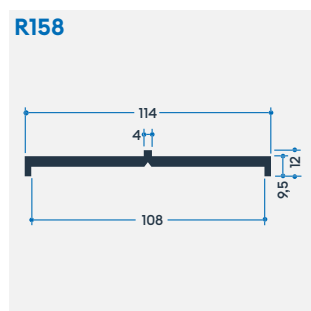
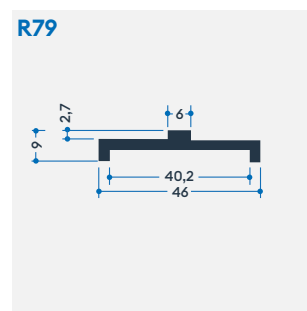
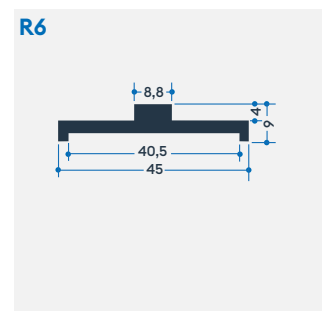
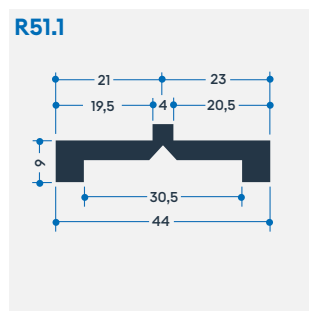
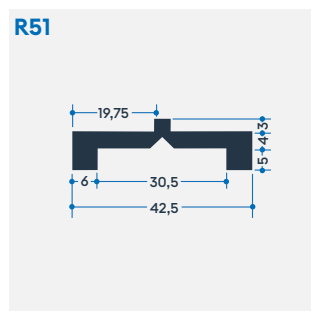
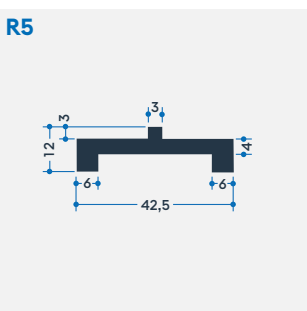
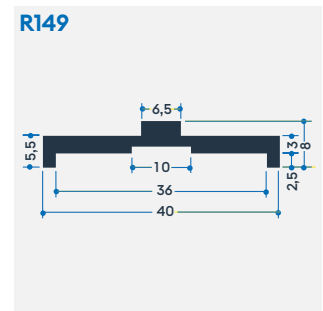
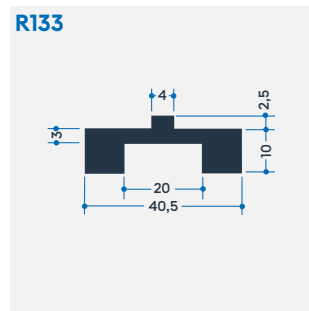
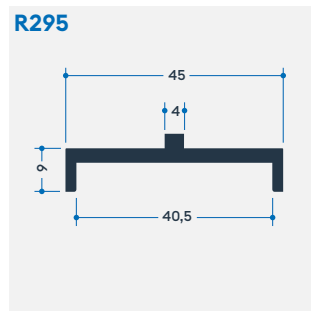
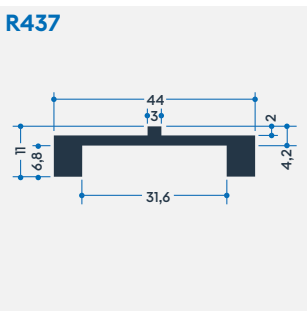
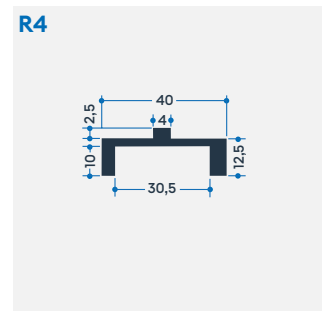
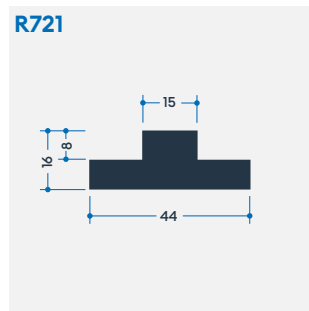
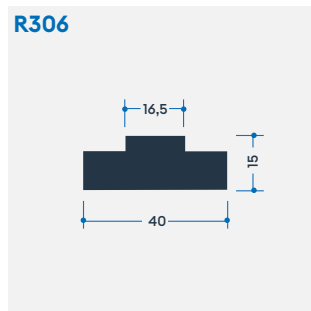
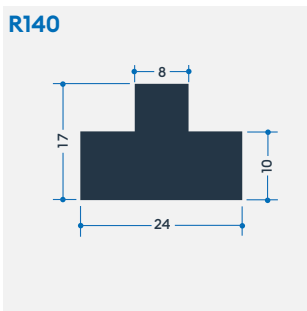
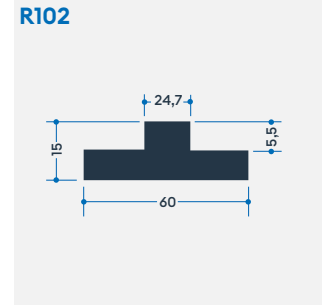
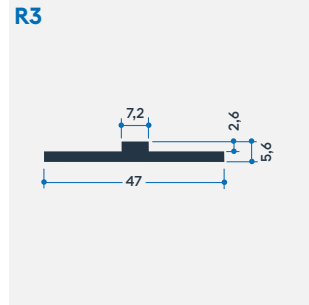
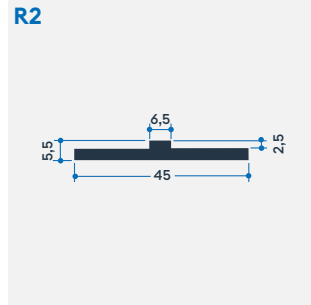
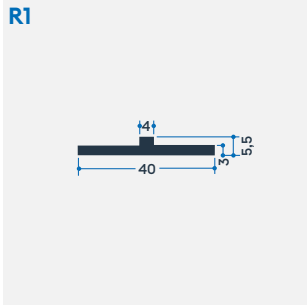

Z-Profil
Z-profiles

L-Profil (Winkel)
L-profiles (angles)

Klemmprofil
Clamp-profiles

T-Profil
T-profiles

U-Profil
U-profiles

C-Profil
C-profiles

Halbrund-Profil
Round bar cover

Rohr
Tubes

Seitenführungsprofil
Side guide profiles

Vierkant-Profil
Square-profiles

Clip-Profil
Clip-profiles

Spezial-Profil
Special-profiles

Bandmaterial
Wear strips

Folien
Film

U-Profile U-profiles

Rollenlänge ca. 60 m
Length per roll ca. 60 m

Standardlänge: 6000 mm oder Rollenware
Qualitäten: M-natur, M-schwarz, M-grün
(PE-UHMW/PE1000)

Standard length: 6000 mm or in coils
Qualities: M-natural, M-black, M-green
(PE-UHMW/PE1000)

Toleranzen nach DIN 16941-3a
und/oder gesonderter
Vereinbarung

Tolerances according to
DIN 16941-3a and/or
separate agreement

R729

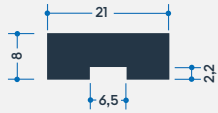

R146



R768

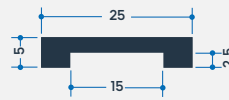

R24

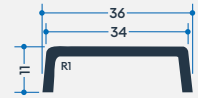

R529

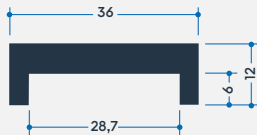

R231

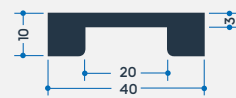

R527

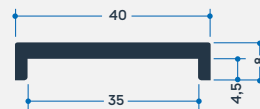

R246

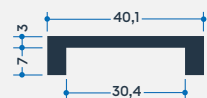

R123

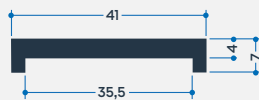

R148

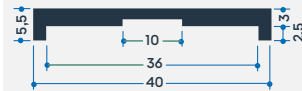

R132

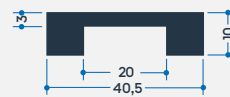

R269



R651



R344

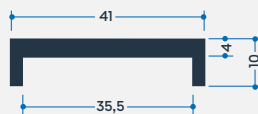

R128

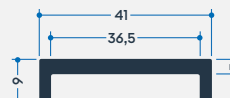

R63

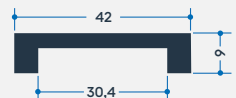

R117

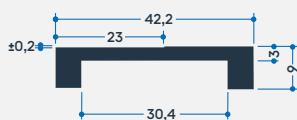

R98

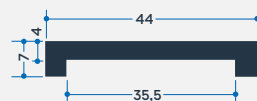

R296

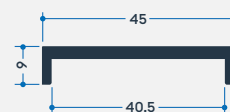

R773

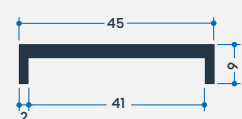

U-Profile U-profiles

Rollenlänge ca. 60 m
Length per roll ca. 60 m

Standardlänge: 6000 mm oder Rollenware
Qualitäten: M-natur, M-schwarz, M-grün
(PE-UHMW/PE 1000)

Standard length: 6000 mm or in coils
Qualities: M-natural, M-black, M-green
(PE-UHMW/PE 1000)

Toleranzen nach DIN 16941-3a
und/oder gesonderter
Vereinbarung

Tolerances according to
DIN 16941-3a and/or
separate agreement

R408

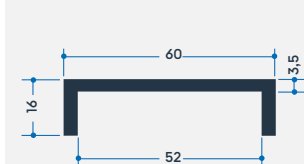

R173

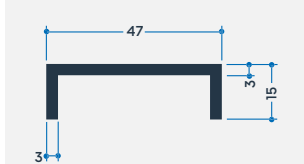

R441

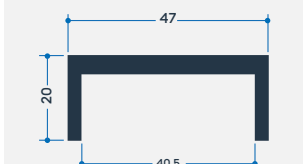

R700

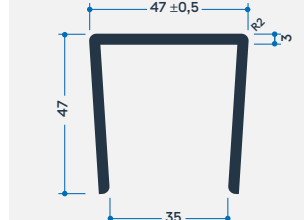

R210

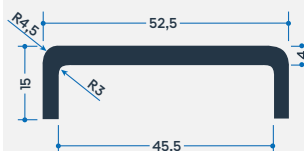

R530

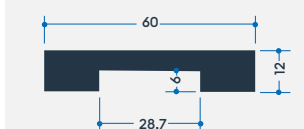

R216

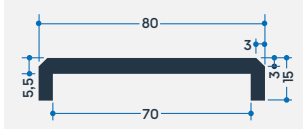

R255

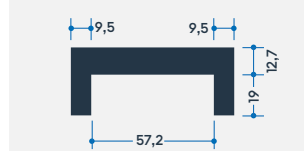

R256

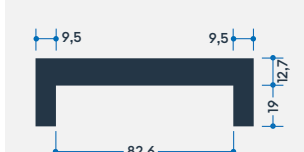

R557

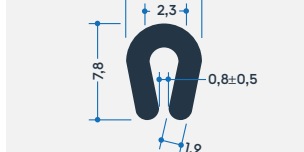

R720

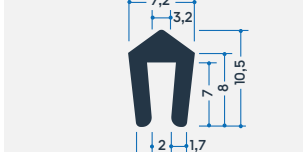

R594

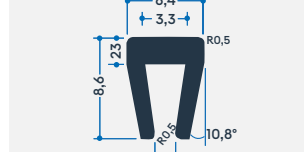

R764

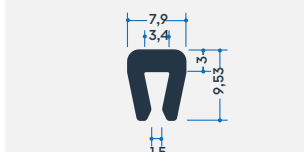

R219

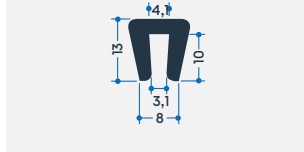

R655

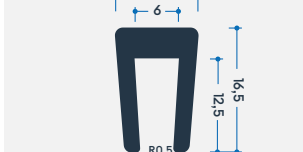

R417

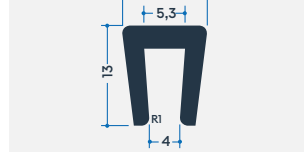

R413

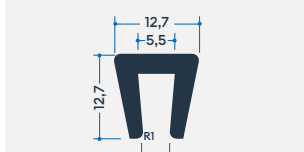

R23

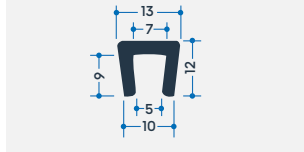

R802

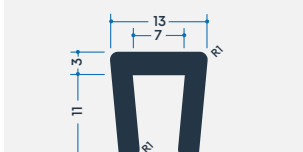

R241

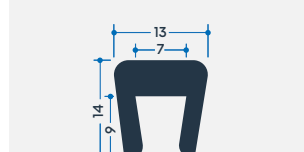

Z-Profile
Z-profiles
L-Profile (Winkel)
L-profiles (angles)
Klemmprofile
Clamp-profiles
T-Profile
T-profiles
U-Profile
U-profiles
C-Profile
C-profiles
Halbrund-Profil
Round bar cover
Rohre
Tubes
Seitenführungsprofil
Side guide profiles
Vierkant-profil
Square-profiles
Clip-Profile
Clip-profiles
Spezial-Profile
Special-profiles
Bandmaterial
Wear strips
Folien
Film

U-Profile U-profiles

Rollenlänge ca. 60 m
Length per roll ca. 60 m

Standardlänge: 6000 mm oder Rollenware
Qualitäten: M-natur, M-schwarz, M-grün
(PE-UHMW/PE1000)

Standard length: 6000 mm or in coils
Qualities: M-natural, M-black, M-green
(PE-UHMW/PE1000)

Toleranzen nach DIN 16941-3a
und/oder gesonderter
Vereinbarung

Tolerances according to
DIN 16941-3a and/or
separate agreement

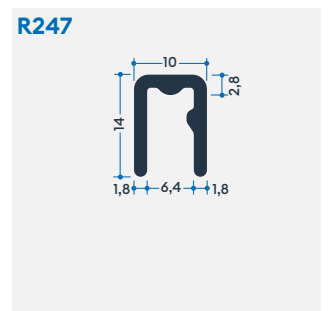
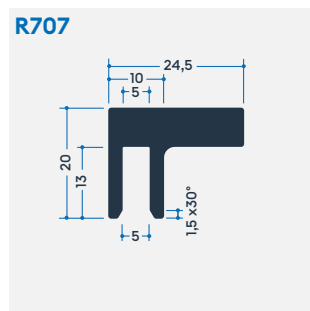
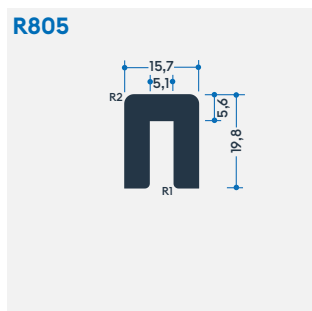
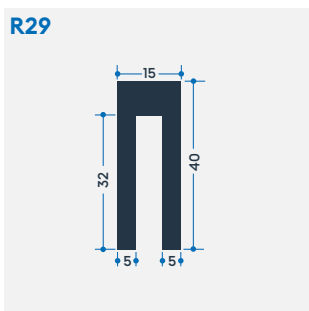
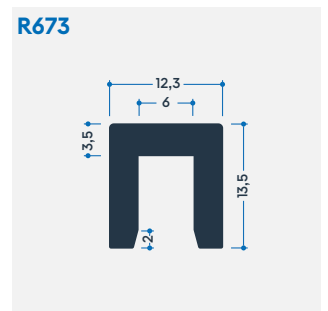
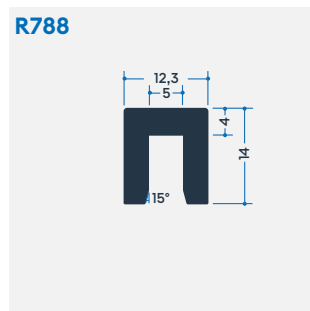
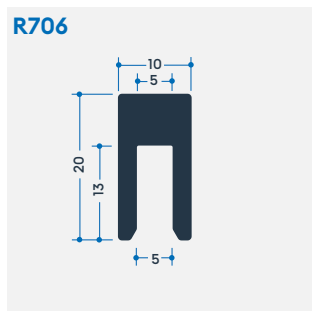
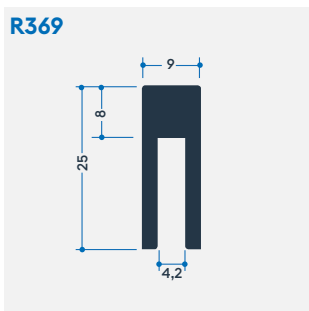
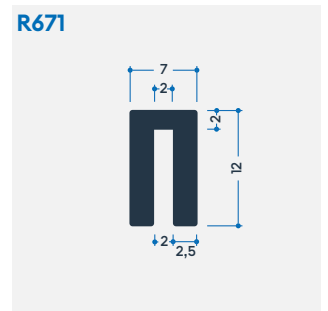
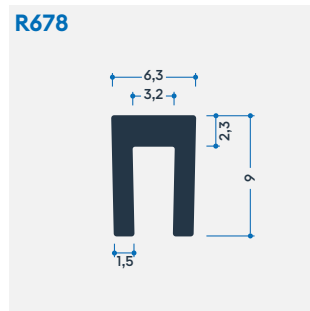
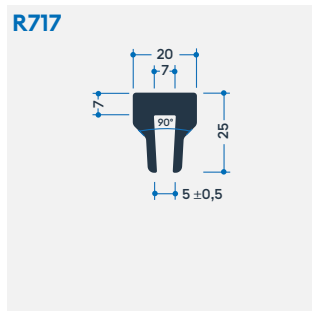
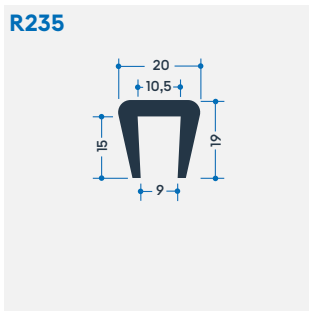
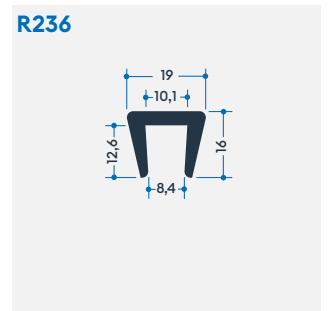
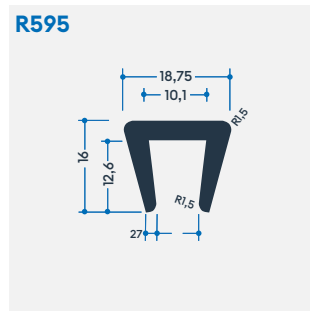
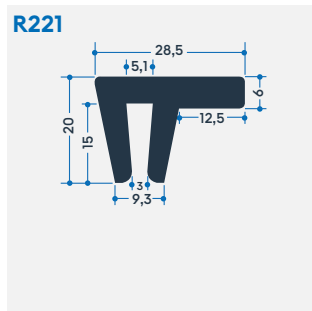
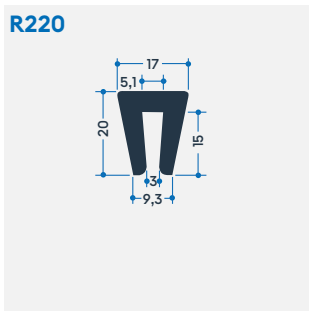
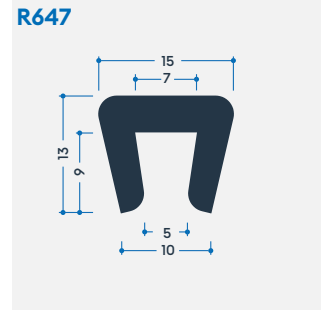
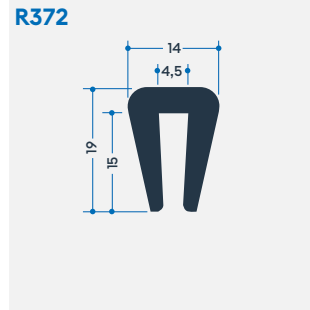
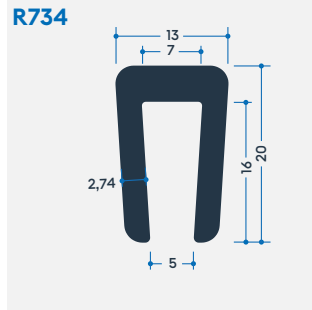
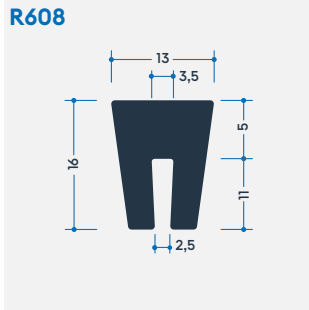

U-Profile U-profiles

Rollenlänge ca. 60 m
Length per roll ca. 60 m

Standardlänge: 6000 mm oder Rollenware
Qualitäten: M-natur, M-schwarz, M-grün
(PE-UHMW/PE 1000)

Standard length: 6000 mm or in coils
Qualities: M-natural, M-black, M-green
(PE-UHMW/PE 1000)

Toleranzen nach DIN 16941-3a
und/oder gesonderter
Vereinbarung

Tolerances according to
DIN 16941-3a and/or
separate agreement

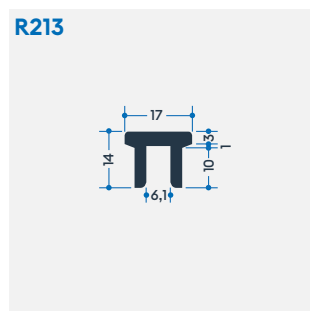
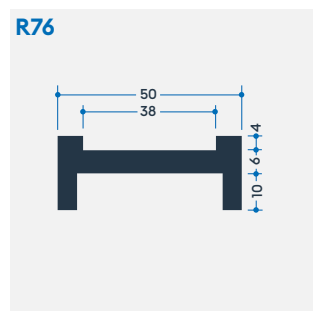
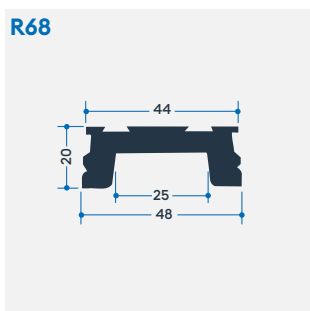
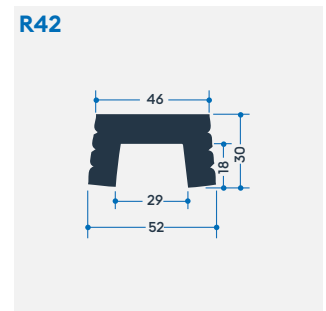
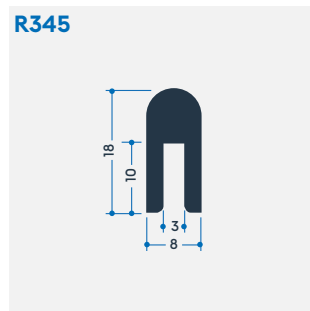
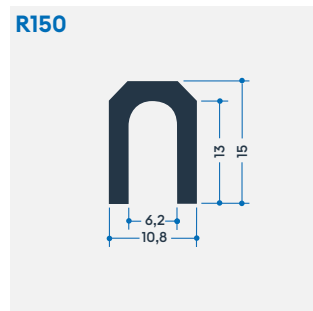
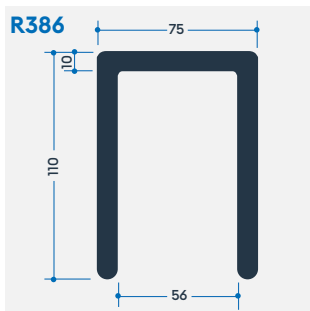
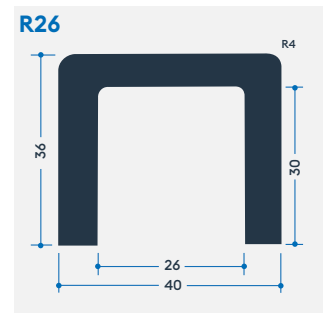
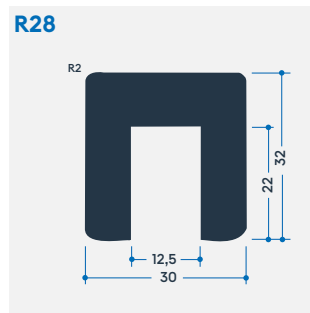
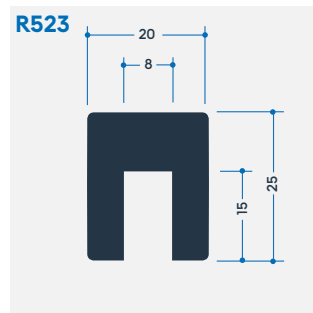
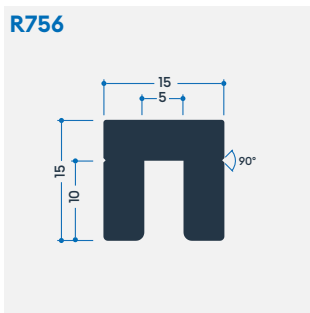
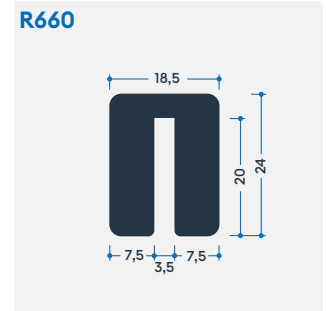
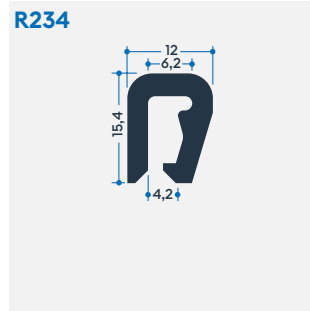
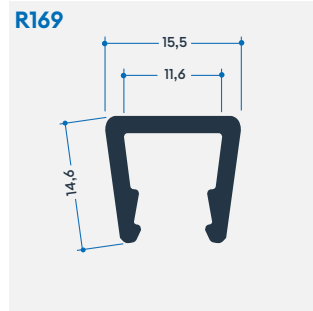
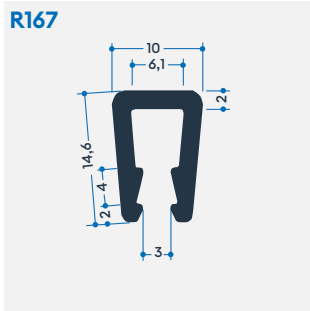

- Z-Profil
Z-profiles
- L-Profil (Winkel)
L-profiles (angles)
- Klemmprofil
Clamp-profiles
- T-Profil
T-profiles
- U-Profil
U-profiles
- C-Profil
C-profiles
- Halbrund-Profil
Round bar cover
- Rohr
Tubes
- Seitenführungsprofil
Side guide profiles
- Vierkantprofil
Square-profiles
- Clip-Profil
Clip-profiles
- Spezial-Profil
Special-profiles
- Bandmaterial
Wear strips
- Folien
Film

C-Profile C-profiles

Rollenlänge ca. 60 m
Length per roll ca. 60 m

Standardlänge: 6000 mm oder Rollenware
Qualitäten: M-natur, M-schwarz, M-grün
(PE-UHMW/PE1000)

Standard length: 6000 mm or in coils
Qualities: M-natural, M-black, M-green
(PE-UHMW/PE1000)

Toleranzen nach DIN 16941-3a
und/oder gesonderter
Vereinbarung

Tolerances according to
DIN 16941-3a and/or
separate agreement

R431

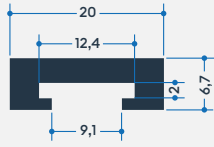

R626

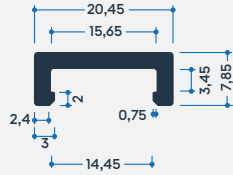

R744

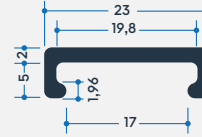

R15

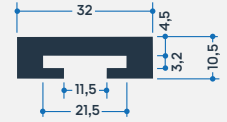

Für Flachstahl 20 x 3
for flat steel 20 x 3

R545

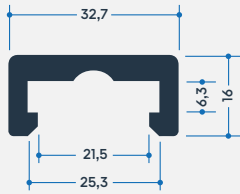

R783

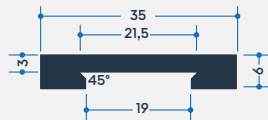

R226

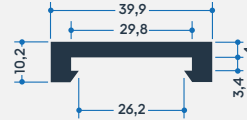

Für Flachstahl 30 x 3
for flat steel 30 x 3

R172

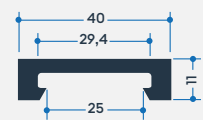

R536

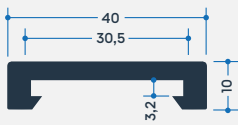

R381

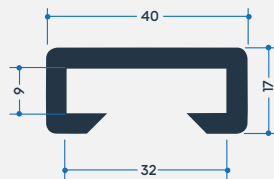

R338

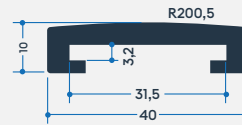

R533

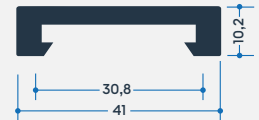

R16

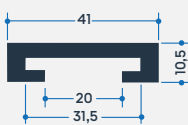

Für Flachstahl 30 x 3
for flat steel 30 x 3

R127

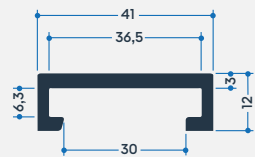

Für Flachstahl 35 x 6
for flat steel 35 x 6

R619

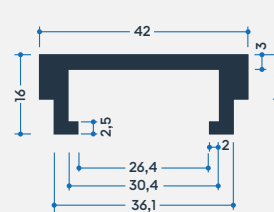

R341

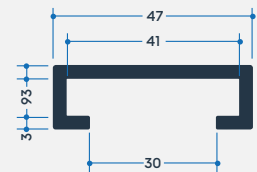

R112

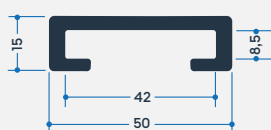

Für Flachstahl 40 x 8
for flat steel 40 x 8

R227

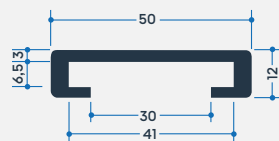

Für Flachstahl 40 x 6
for flat steel 40 x 6

R21

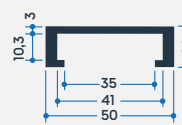

Für Flachstahl 40 x 10
for flat steel 40 x 10

R331

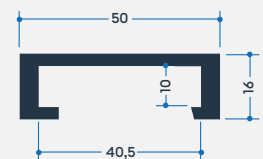

Für Flachstahl 40 x 10
for flat steel 40 x 10

C-Profile C-profiles

Rollenlänge ca. 60 m
Length per roll ca. 60 m

Standardlänge: 6000 mm oder Rollenware
Qualitäten: M-natur, M-schwarz, M-grün
(PE-UHMW/PE 1000)

Standard length: 6000 mm or in coils
Qualities: M-natural, M-black, M-green
(PE-UHMW/PE 1000)

Toleranzen nach DIN 16941-3a
und/oder gesonderter
Vereinbarung

Tolerances according to
DIN 16941-3a and/or
separate agreement

R160

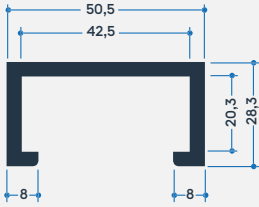

R276

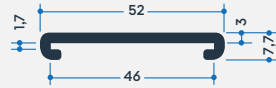

R790

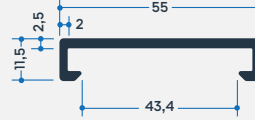

R750

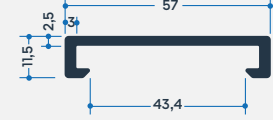

R759

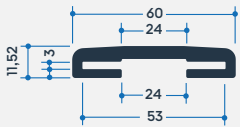

R94

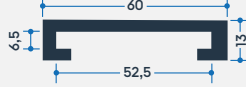

Für Flachstahl 50 x 6
for flat steel 50 x 6

R18

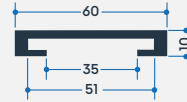

Für Flachstahl 50 x 4
for flat steel 50 x 4

R120

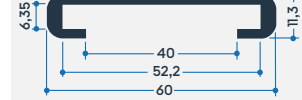

Für Flachstahl 50 x 6
for flat steel 50 x 6

R674

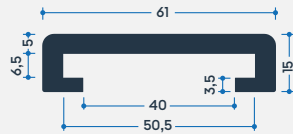

R19

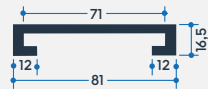

Für Flachstahl 70 x 6
for flat steel 70 x 6

R244

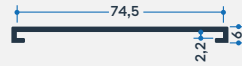

R373

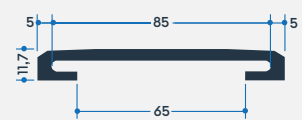

R668

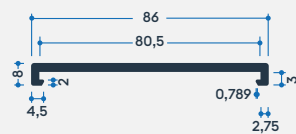

R265



Für Flachstahl 80 x 5
for flat steel 80 x 5

R716

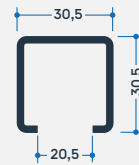

R289

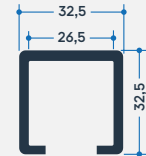

R727

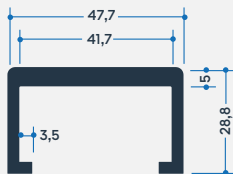

R585

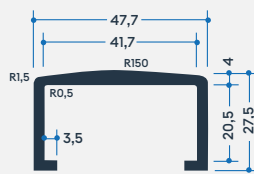

R603

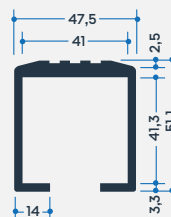

R260

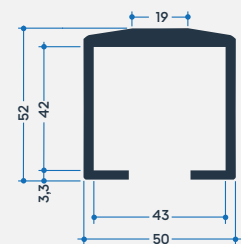

Z-Profile
Z-profiles

L-Profile (Winkel)
L-profiles (angles)

Klemmprofile
Clamp-profiles

T-Profile
T-profiles

U-Profile
U-profiles

C-Profile
C-profiles

Halbrund-Profile
Round bar cover

Rohre
Tubes

Seitenführungsprofile
Side guide profiles

Vierkant-profile
Square-profiles

Clip-Profile
Clip-profiles

Spezial-Profile
Special-profiles

Bandmaterial
Wear strips

Folien
Film

C-Profile C-profiles

Rollenlänge ca. 60 m
Length per roll ca. 60 m

Standardlänge: 6000 mm oder Rollenware
Qualitäten: M-natur, M-schwarz, M-grün
(PE-UHMW/PE 1000)

Standard length: 6000 mm or in coils
Qualities: M-natural, M-black, M-green
(PE-UHMW/PE 1000)

Toleranzen nach DIN 16941-3a
und/oder gesonderter
Vereinbarung

Tolerances according to
DIN 16941-3a and/or
separate agreement

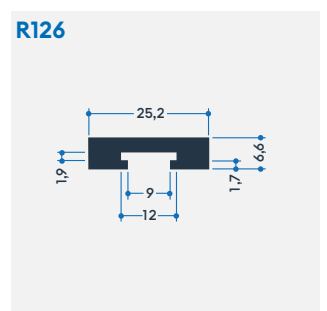
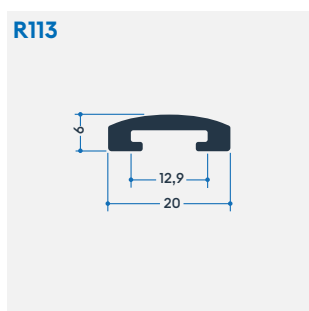
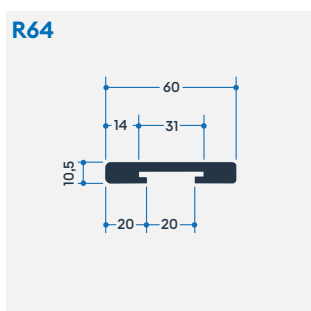
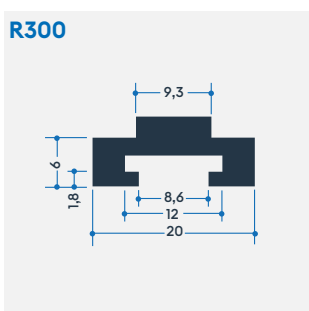
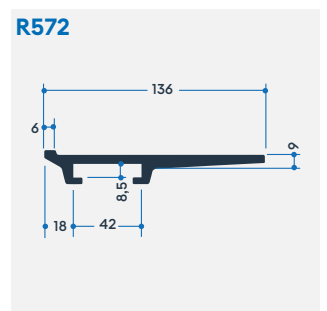
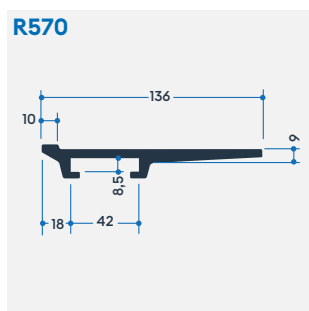
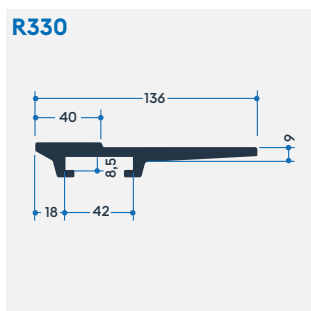
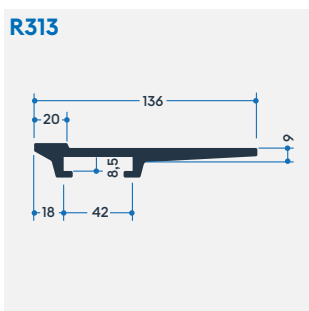
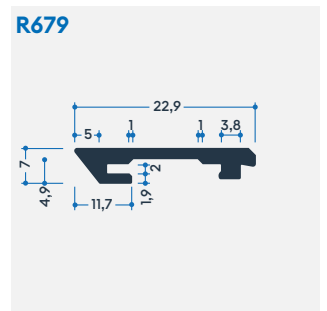
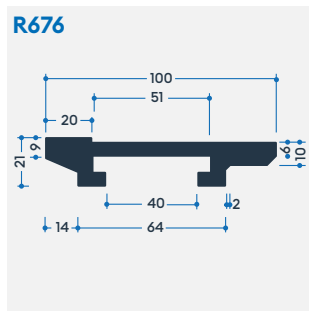
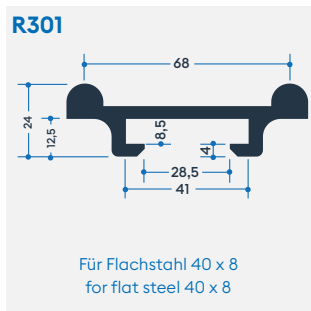
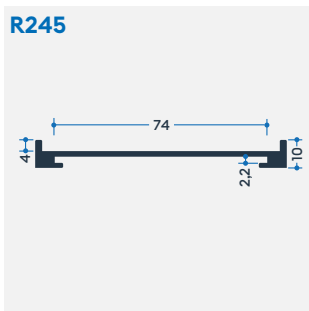
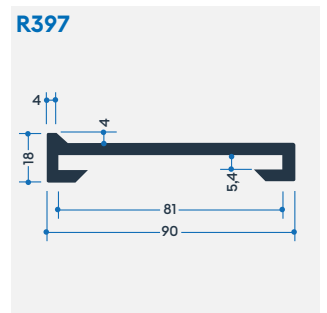
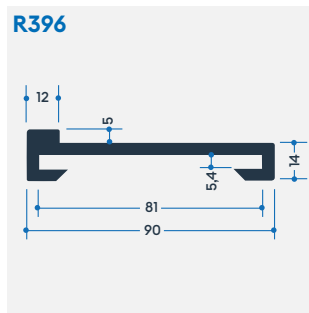
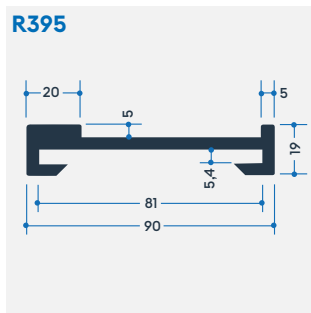
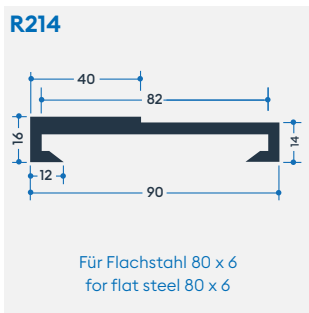
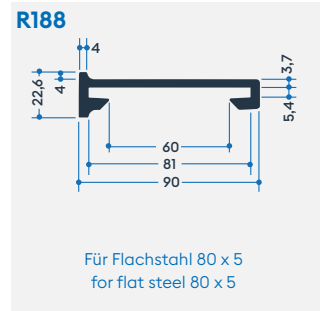
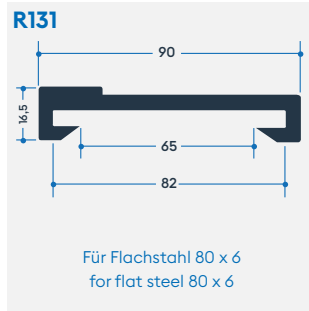
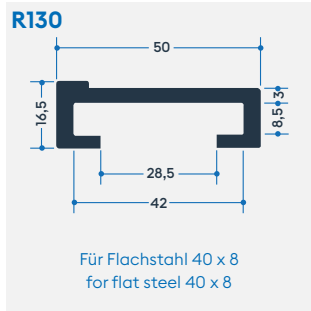
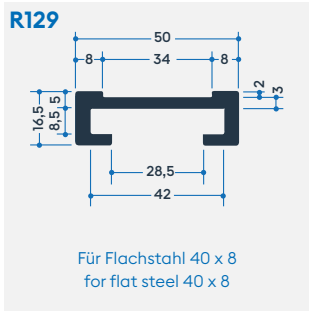

C-Profile C-profiles

Rollenlänge ca. 60 m
Length per roll ca. 60 m

Standardlänge: 6000 mm oder Rollenware
Qualitäten: M-natur, M-schwarz, M-grün
(PE-UHMW/PE 1000)

Standard length: 6000 mm or in coils
Qualities: M-natural, M-black, M-green
(PE-UHMW/PE 1000)

Toleranzen nach DIN 16941-3a
und/oder gesonderter
Vereinbarung

Tolerances according to
DIN 16941-3a and/or
separate agreement

R363

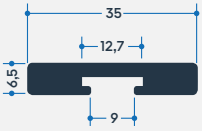

R428

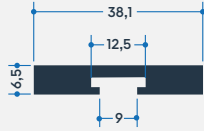

R115

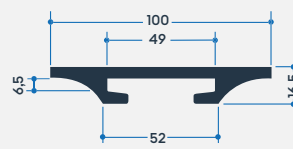

R785

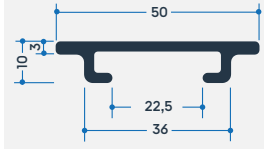

R786

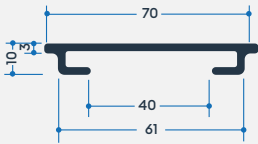

R443

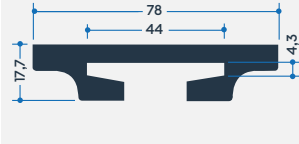

R579

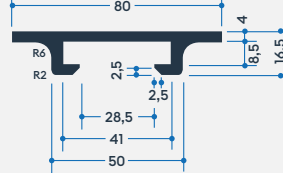

R353

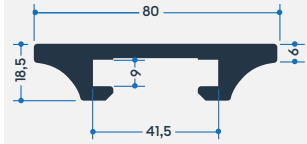

R240

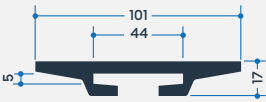

R111

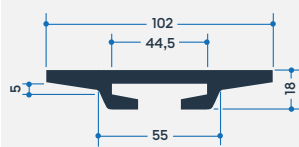

R554



R571

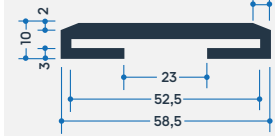

R620

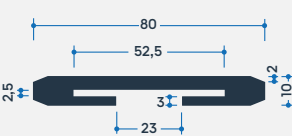

R412

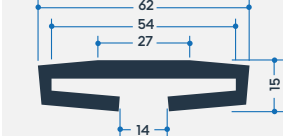

R430

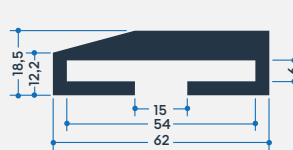

R758

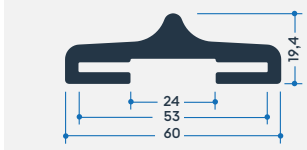

R757

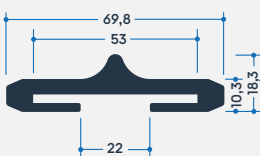

R691

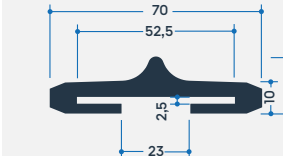

R772

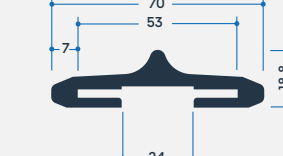

R621

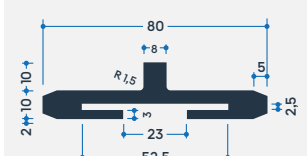

Z-Profile
Z-profiles

L-Profile (Winkel)
L-profiles (angles)

Klemmprofile
Clamp-profiles

T-Profile
T-profiles

U-Profile
U-profiles

C-Profile
C-profiles

Halbrund-Profil
Round bar cover

Rohre
Tubes

Seitenführungsprofil
Side guide profiles

Vierkant-Profil
Square-profiles

Clip-Profil
Clip-profiles

Spezial-Profil
Special-profiles

Bandmaterial
Wear strips

Folien
Film

C-Profile C-profiles

Rollenlänge ca. 60 m
Length per roll ca. 60 m

Standardlänge: 6000 mm oder Rollenware
Qualitäten: M-natur, M-schwarz, M-grün
(PE-UHMW/PE1000)

Standard length: 6000 mm or in coils
Qualities: M-natural, M-black, M-green
(PE-UHMW/PE1000)

Toleranzen nach DIN 16941-3a
und/oder gesonderter
Vereinbarung

Tolerances according to
DIN 16941-3a and/or
separate agreement

R726

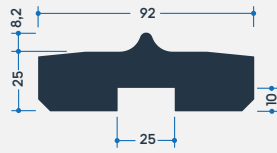

R272

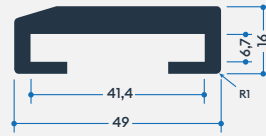

R770

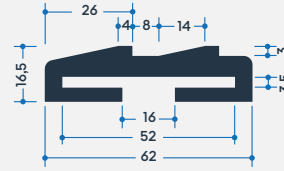

R22

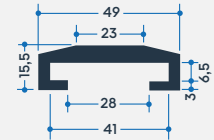

R548

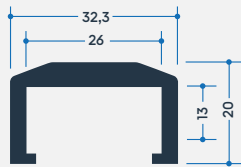

R777

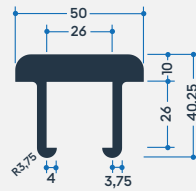

R528

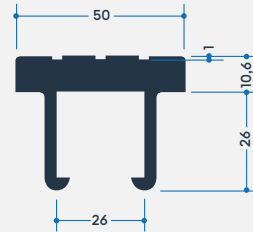

R765

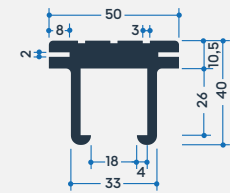

Halbrund-Profil Round bar cover

Standardlänge: 6000 mm oder Rollenware
Qualitäten: M-natur, M-schwarz, M-grün
(PE-UHMW/PE 1000)

Standard length: 6000 mm or in coils
Qualities: M-natural, M-black, M-green
(PE-UHMW/PE 1000)

Toleranzen nach DIN 16941-3a
und/oder gesonderter
Vereinbarung

Tolerances according to
DIN 16941-3a and/or
separate agreement

R425

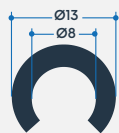

Für Rundstab ø 10 mm
for roundbar ø 10 mm

R735

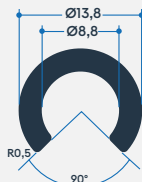

R95



Für Rundstab ø 10 mm
for roundbar ø 10 mm

R11

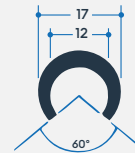

Für Rundstab ø 12 mm
for roundbar ø 12 mm

R592

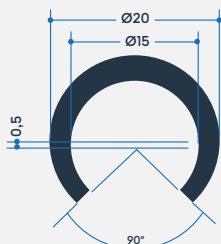

R774

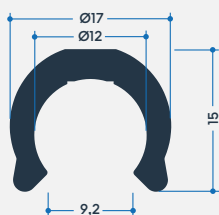

R97

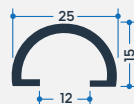

Rollenlänge ca. 60 m
Length per roll ca. 60 m

R283

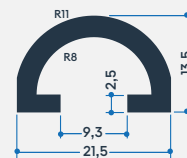

Rollenlänge ca. 60 m
Length per roll ca. 60 m

Z-Profil
Z-profiles

L-Profil (Winkel)
L-profiles (angles)

Klemmprofil
Clamp-profiles

T-Profil
T-profiles

U-Profil
U-profiles

C-Profil
C-profiles

Halbrund-Profil
Round bar cover

Rohr
Tubes

Seitenführungsprofil
Side guide profiles

Vierkantprofil
Square-profiles

Clip-Profil
Clip-profiles

Spezial-Profil
Special-profiles

Bandmaterial
Wear strips

Folien
Film

Rohre Tubes

Standardlänge: 6000 mm oder Rollenware
Qualitäten: M-natur, M-schwarz, M-grün
(PE-UHMW/PE 1000)

Standard length: 6000 mm or in coils
Qualities: M-natural, M-black, M-green
(PE-UHMW/PE 1000)

Toleranzen nach DIN 16941-3a
und/oder gesonderter
Vereinbarung

Tolerances according to
DIN 16941-3a and/or
separate agreement

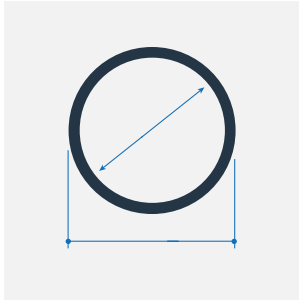

Profile Profiles	Außendurchmesser Outside diameter	Innendurchmesser Inside diameter
R390	28	22,8
R346	43	37
R669	50	18,5
R511	50,6	30,8
R307	51	44
R308	63	55
R314	80	67
R680	83	30
R347	90	80
R358	97,2	78,9
R383	100	90
R366	128	104
R348	136	120
R661	148	126
R367	160	136
R368	200	176

Seitenführungsprofile

Side guide profiles

Standardlänge: 6000 mm oder Rollenware
 Qualitäten: M-natur, M-schwarz, M-grün
 (PE-UHMW/PE 1000)

Standard length: 6000 mm or in coils
 Qualities: M-natural, M-black, M-green
 (PE-UHMW/PE 1000)

Toleranzen nach DIN 16941-3a
 und/oder gesonderter Verein-
 barung

Tolerances according to
 DIN 16941-3a and/or
 separate agreement

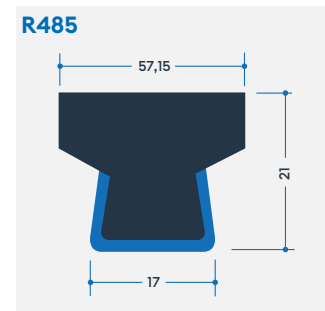
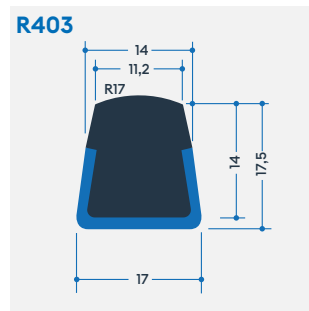
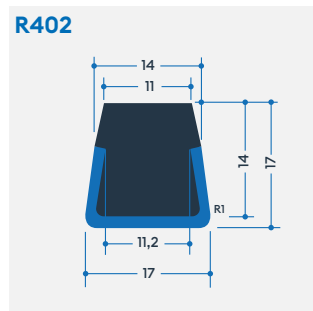
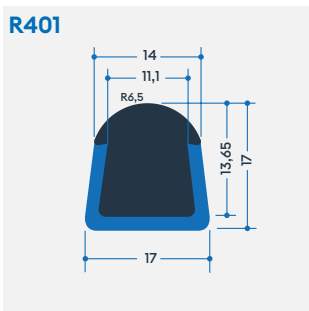
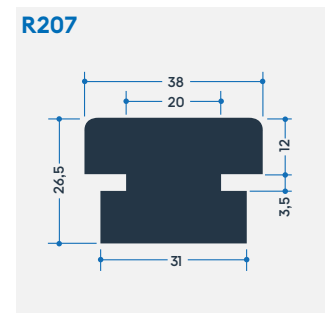
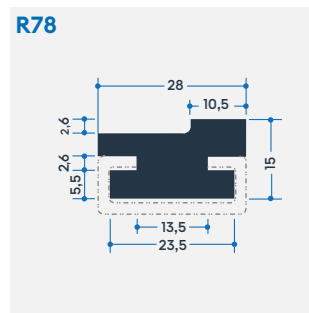
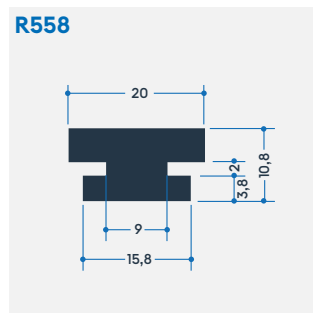
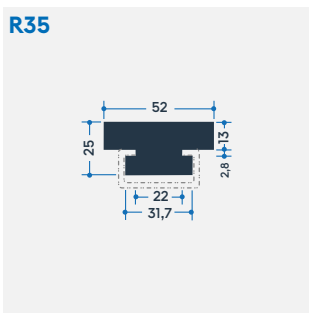
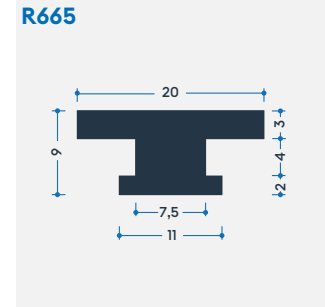
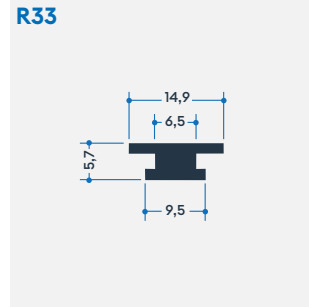
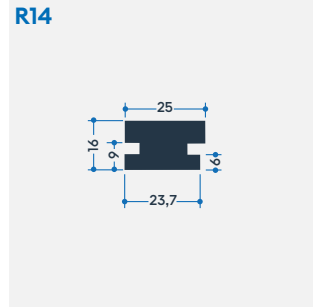
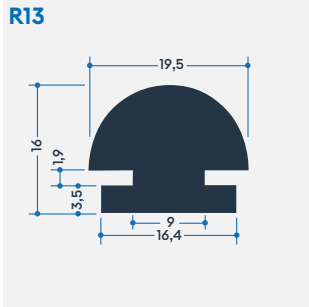

Z-Profil	Z-profiles
L-Profil (Winkel)	L-profiles (angles)
Klemmprofil	Clamp-profiles
T-Profil	T-profiles
U-Profil	U-profiles
C-Profil	C-profiles
Halbrund-Profil	Round bar cover
Rohr	Tubes
Seitenführungsprofil	Side guide profiles
Vierkant-Profil	Square-profiles
Clip-Profil	Clip-profiles
Spezial-Profil	Special-profiles
Bandmaterial	Wear strips
Folien	Film

Vierkant-Profile Square-profiles

Rollenlänge ca. 60 m
Length per roll ca. 60 m

Standardlänge: 6000 mm oder Rollenware
Qualitäten: M-natur, M-schwarz, M-grün
(PE-UHMW/PE 1000)

Standard length: 6000 mm or in coils
Qualities: M-natural, M-black, M-green
(PE-UHMW/PE 1000)

Toleranzen nach DIN 16941-3a
und/oder gesonderter
Vereinbarung

Tolerances according to
DIN 16941-3a and/or
separate agreement

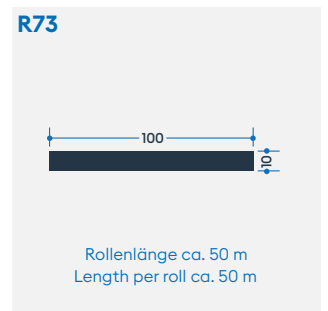
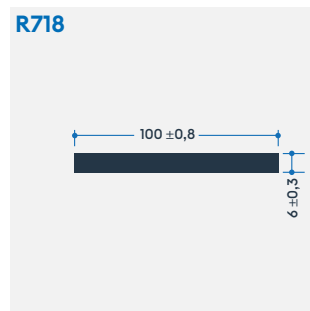
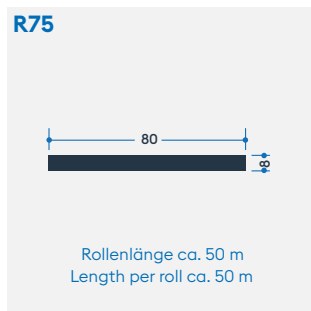
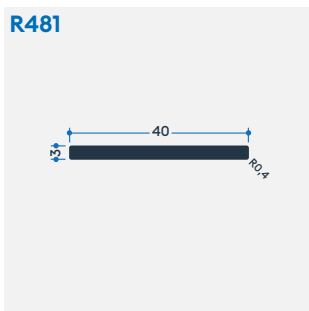
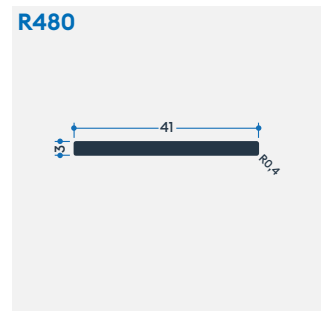
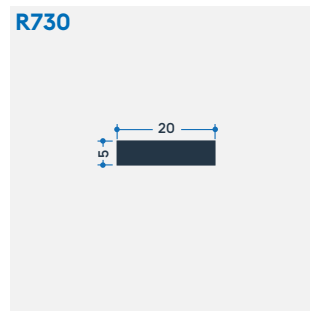
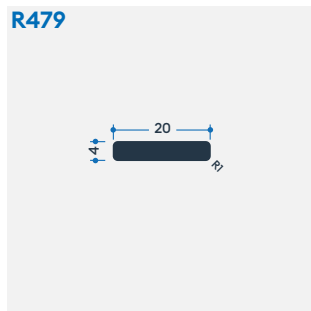
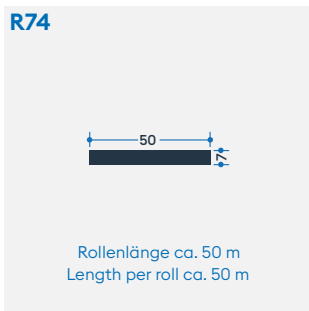
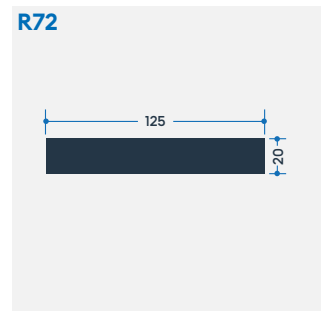
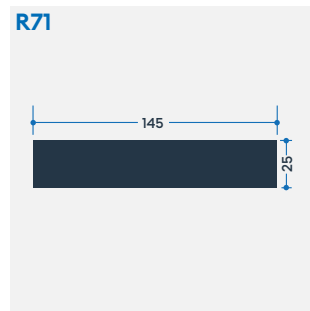
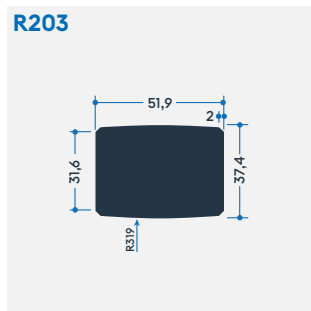
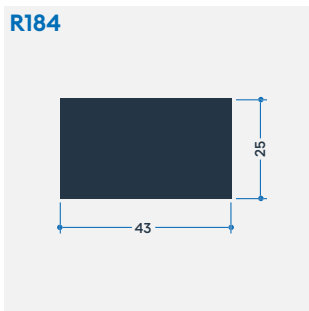
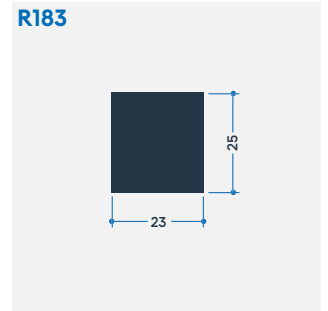
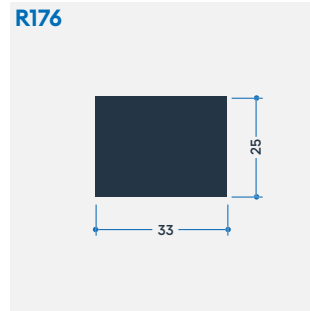
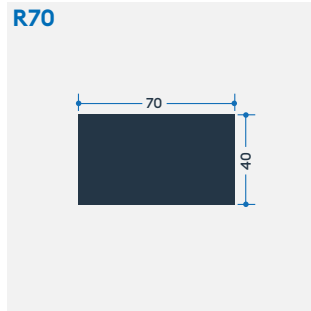
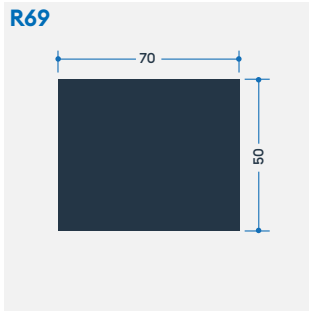

Clip-Profile Clip-profiles

Standardlänge: 6000 mm oder Rollenware
Qualitäten: M-natur, M-schwarz, M-grün
(PE-UHMW/PE 1000)

Standard length: 6000 mm or in coils
Qualities: M-natural, M-black, M-green
(PE-UHMW/PE 1000)

Toleranzen nach DIN 16941-3a und/oder gesonderter Vereinbarung

Tolerances according to DIN 16941-3a and/or separate agreement

R782

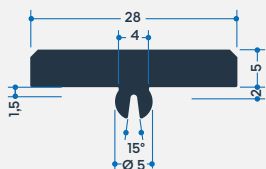

R77

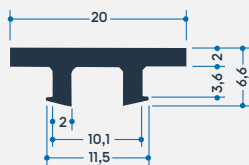

R249

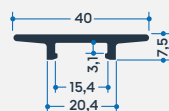

R156

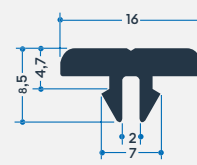

R90

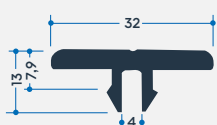

R157

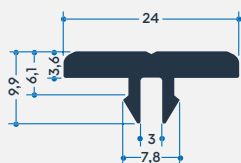

R597

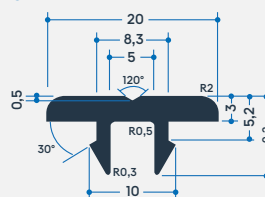

R598

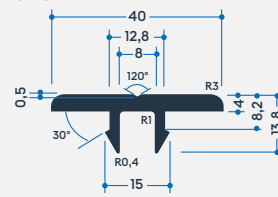

R715

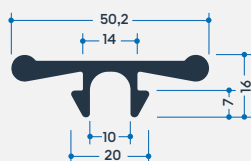

R196

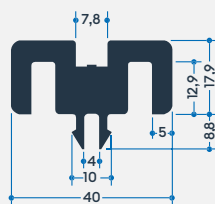

R197

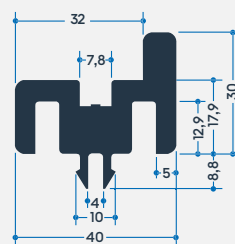

R250

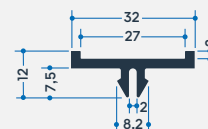

R87

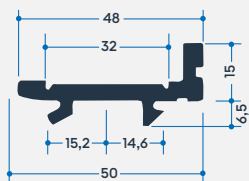

Z-Profile	Z-profiles
L-Profile (Winkel)	L-profiles (angles)
Klemmprofile	Clamp-profiles
T-Profile	T-profiles
U-Profile	U-profiles
C-Profile	C-profiles
Halbrund-Profile	Round bar cover
Rohre	Tubes
Seitenführungsprofile	Side guide profiles
Vierkant-profile	Square-profiles
Clip-Profile	Clip-profiles
Spezial-Profile	Special-profiles
Bandmaterial	Wear strips
Folien	Film

Spezial-Profile Special-profiles

Standardlänge: 6000 mm oder Rollenware
Qualitäten: M-natur, M-schwarz, M-grün
(PE-UHMW/PE1000)

Standard length: 6000 mm or in coils
Qualities: M-natural, M-black, M-green
(PE-UHMW/PE1000)

Toleranzen nach DIN 16941-3a
und/oder gesonderter
Vereinbarung

Tolerances according to
DIN 16941-3a and/or
separate agreement

R88

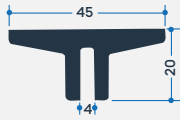

R89

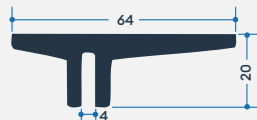

R139

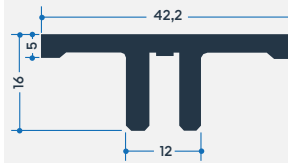

R212

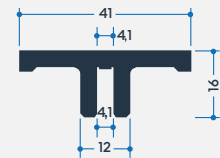

R116

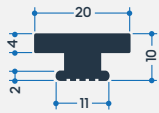

R134

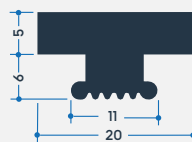

R135

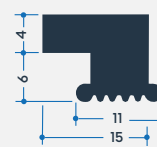

R136

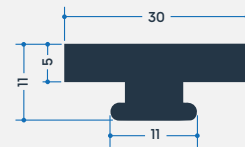

R143

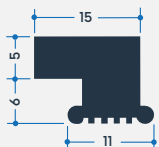

R12

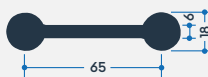

R48

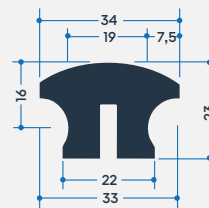

R326

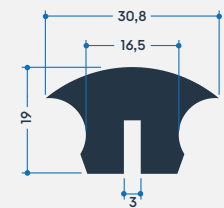

R365

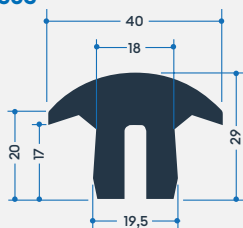

R515

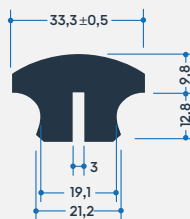

R65

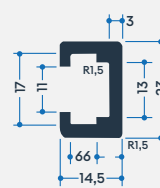

R66

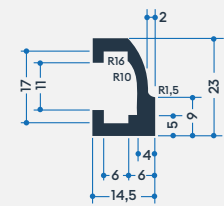

R67

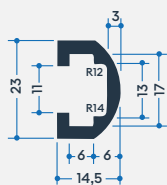

R242



R251

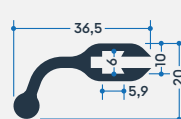

R294

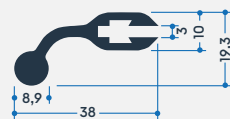

Spezial-Profil Special-profiles

Standardlänge: 6000 mm oder Rollenware
Qualitäten: M-natur, M-schwarz, M-grün
(PE-UHMW/PE 1000)

Standard length: 6000 mm or in coils
Qualities: M-natural, M-black, M-green
(PE-UHMW/PE 1000)

Toleranzen nach DIN 16941-3a
und/oder gesonderter
Vereinbarung

Tolerances according to
DIN 16941-3a and/or
separate agreement

R252

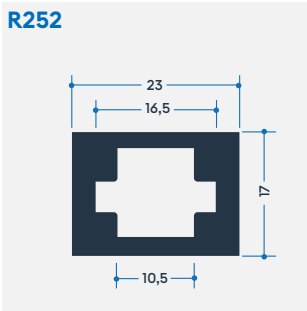

R253

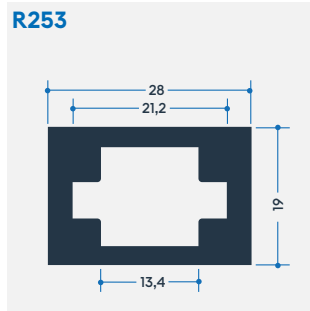

R361

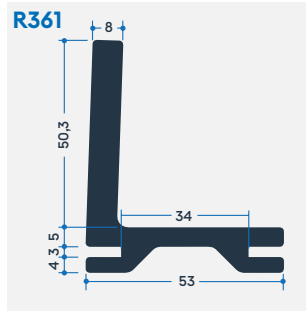

R591

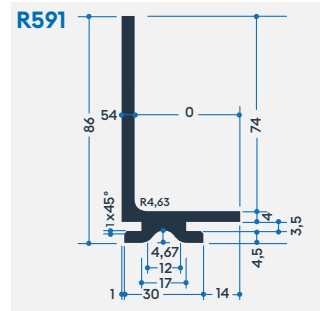

R389

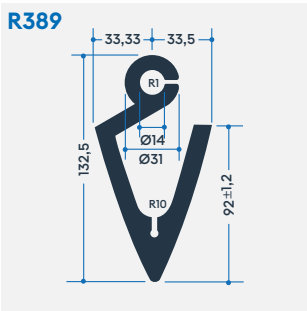

R576

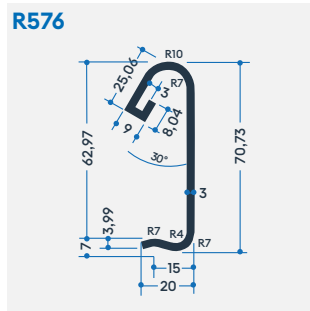

Z-Profil Z-profiles
L-Profil (Winkel) L-profiles (angles)
Klemmprofil Clamp-profiles
T-Profil T-profiles
U-Profil U-profiles
C-Profil C-profiles
Halbrund-Profil Round bar cover
Rohr Tubes
Seitenführungsprofil Side guide profiles
Vierkant-Profil Square-profiles
Clip-Profil Clip-profiles
Spezial-Profil Special-profiles
Bandmaterial Wear strips
Folien Film

Bandmaterial, geschält

Wear strips, skived

- für Ketten nach DIN 8187
- for chains to DIN 8187

Bandbreite Width	Bandlänge bei Banddicke Length at thickness							
	1 mm	2 mm	3 mm	4 mm	5 mm	6 mm	7 mm	8 mm
15								
18							-	-
20								
25								
30								
35								
40	270 m	135 m	85 m	65 m	50 m	40 m	35 m	30 m
45								
50								
55								
60								
70								
80								
90	160 m	80 m	50 m	38 m	32 m	25 m	22 m	-
100								
110								



Bemerkungen: Sonderabmessungen auf Anfrage.
 Max. Abmessungen: 300 mm Breite, 0,25 - 3 mm Dicke.
 Toleranzen: Dicke +0,1/-0,3 mm, Breite $\pm 0,3$ mm

Notes: Special dimensions on request.
 Max. dimension: 300 mm width, 0.25 - 3 mm thickness.
 Tolerances: Thickness +0.1/-0.3 mm, Width ± 0.3 mm

Folien, geschält

Film, skived

Breite ¹⁾ Width ¹⁾	Folienlänge Length	Foliendicke Thickness
mm	m	mm
100 ... 300 mm	136	0,25
	68	0,50
	45	0,75
	34	1,00
	27	1,25
	22	1,50
	19	1,75
	17	2,00
	15	2,25
	13	2,50
	12	2,75
	11	3,00

1) Folien sind in jeder gewünschten Breite von 100 – 300 mm lieferbar

1) Films are deliverable in a width of 100 – 300 mm

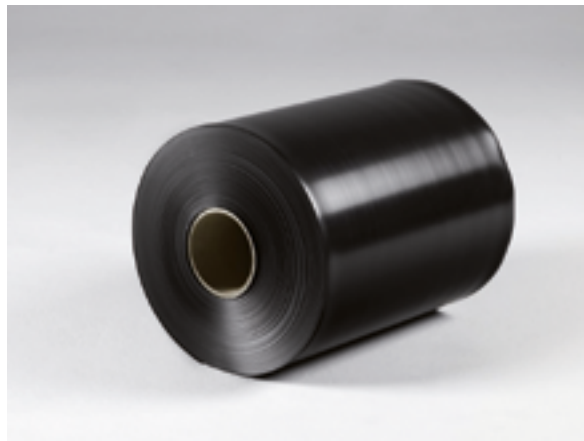

Z-Profil
Z-profiles

L-Profil (Winkel)
L-profiles (angles)

Klemmprofil
Clamp-profiles

T-Profil
T-profiles

U-Profil
U-profiles

C-Profil
C-profiles

Halbrund-Profil
Round bar cover

Rohre
Tubes

Seitenführungsprofil
Side guide profiles

Vierkant-profil
Square-profiles

Clip-Profil
Clip-profiles

Spezial-Profil
Special-profiles

Bandmaterial
Wear strips

Folien
Film

Technische Daten

Technical data

Produktmerkmale

- Hohe Abrieb- und Verschleißfestigkeit
- Geringer Gleitreibungskoeffizient
- Hohe Schlagzähigkeit

Typische Anwendungsbereiche

- Getränke- und Lebensmittelindustrie
- Maschinenbau
- Verpackungsindustrie

Product characteristics

- High abrasion and wear resistance
- Low coefficient of friction
- High impact strength

Product applications

- Beverage and food industry
- Mechanical engineering
- Packaging industry

Eigenschaften Properties	Testmethode Test method	Einheit Unit	Richtwerte Guideline Value
Allg. Eigenschaften General properties			
Dichte Density	DIN EN ISO 1183-1	g/cm ³	> 0,93
Feuchtigkeitsaufnahme Water absorption	DIN EN ISO 62	%	< 0,01
Brennverhalten (Dicke 3 mm / 6 mm) Flammability (Thickness 3 mm / 6 mm)	UL 94	-	HB
Molekulargewicht Molecular weight	-	10 ⁶ g/mol	~ 9
Mechanische Eigenschaften Mechanical properties			
Reißdehnung Elongation at break	DIN EN ISO 527	%	> 50
E-Modul Tensile modulus of elasticity	DIN EN ISO 527	MPa	> 650
Kerbschlagzähigkeit Notched impact strength	DIN EN ISO 11542	kJ/m ²	> 100
Shore Härte Shore hardness	DIN EN ISO 868	scale D	> 63
Thermische Eigenschaften Thermal properties			
Schmelztemperatur Melting temperature	ISO 11357-3	°C	130 ... 135
Wärmeleitfähigkeit Thermal conductivity	DIN 52612-1	W/(m*K)	0,40
Wärmekapazität Thermal capacity	DIN 52612	kJ (kg*K)	1,90
Linearer Ausdehnungskoeffizient Coefficient of linear thermal expansion	DIN 53752	10 ⁻⁶ /K	150 ... 230
Einsatztemperatur langfristig Service temperature, long term	Average	°C	- 250 ... 80
Einsatztemperatur kurzfristig (max.) Service temperature, short term (max.)	Average	°C	130
Vicat Erweichungstemperatur Vicat softening temperature	DIN EN ISO 306, Vicat B	°C	80
Elektrische Eigenschaften Electrical properties			
Dielektrizitätszahl Dielectric constant	IEC 60250	-	2,3
Dielektrischer Verlustfaktor (10⁶ Hz) Dielectric dissipation factor (10 ⁶ Hz)	IEC 60250	-	0,0001
Durchgangswiderstand Volume resistivity	DIN EN 62631-3-1	Ω*cm	> 10 ¹⁴
Oberflächenwiderstand Surface resistivity	DIN EN 62631-3-2	Ω	> 10 ¹⁴
Vergleichszahl der Kriechwegbildung Comparative tracking index	IEC 60112	-	600
Durchschlagfestigkeit Dielectric strength	IEC 60243	kV/mm	> 40

Bei den angegebenen Werten handelt es sich um Mittelwerte, die durch ständige statistische Prüfungen abgesichert sind. Sie entsprechen den Vorgaben der DIN EN 15860. Diese Daten sind reine Beschaffenheitsangaben und führen nur bei ausdrücklicher Vereinbarung zu kaufvertraglicher Zusage.

The data stated above are average values ascertained by statistical tests on a regular basis. They are in accordance with DIN EN 15860. The data above are provided purely for information and shall not be regarded as binding unless expressly agreed in a contract of sale.

Allgemeine Hinweise

Alle in diesem Lieferprogramm enthaltenen Informationen wurden nach bestem Wissen recherchiert. Dennoch sind Fehler nicht ganz auszuschließen. Aus diesem Grunde sind die im vorliegenden Lieferprogramm enthaltenen Informationen mit keiner Verpflichtung oder Garantie irgendeiner Art verbunden. Wir übernehmen daher infolgedessen keine Verantwortung und werden keine daraus folgende oder sonstige Haftung für Schäden übernehmen, die auf irgendeine Art aus der Benutzung dieser Informationen entstehen. Auch für die Vollständigkeit der erfassten Produkte, Verfahren, Eigenschaften etc. kann keine Gewähr übernommen werden.

Dieses Werk ist urheberrechtlich geschützt. Alle Rechte, auch die der Übersetzung, des Nachdrucks und der Vervielfältigung und/oder Teilen daraus sind Röchling Industrial vorbehalten. Kein Teil des Werkes darf ohne schriftliche Genehmigung von Röchling Industrial, egal zu welchem Zweck oder in welchem Medium, vervielfältigt, verarbeitet oder verbreitet werden.

Mit Erscheinen dieses Drucks verlieren frühere Ausgaben ihre Gültigkeit.

© 2018 Röchling

General Information

All information contained in this delivery programme has been researched to the best of our ability. Despite our best efforts, this does not exclude the possibility of errors. For this reason, the information contained in this supply range is unconditional and carries no guarantees of any kind. Therefore, we assume absolutely no liability for any damages resulting from this information, nor any other form of liability, which in any way results from the information contained herein. We assume no liability for the completeness of the included products and information, processes, properties, etc.

This work is protected by copyright. Röchling reserves all rights, including those for the translation, reprints and the reproduction and/or excerpting herefrom. No part of this work is permitted to be copied, processed or distributed, regardless of intended purpose or medium, without the express written consent of Röchling Industrial.

Upon publication of this document all previous editions shall become void.

© 2018 Röchling



Unsere Standorte weltweit

Finden Sie hier die Niederlassung für Ihre Region.
Einfach QR-Code scannen.

Our locations worldwide

Scan the QR code to find the
subsidiary for your region.